



Planmeca Viso™

user's manual

Table of contents

1	Introduction.....	1
1.1	Device description.....	1
1.2	Intended use.....	1
2	Associated documentation.....	2
3	Product registration.....	3
4	Symbols.....	4
4.1	Symbols on product labels.....	4
5	Safety precautions.....	5
6	Pediatric use.....	11
6.1	Introduction.....	11
6.2	References for pediatric dose optimisation.....	11
6.3	Device specific features and instructions.....	11
7	Switching X-ray system on.....	13
7.1	Switching X-ray unit on.....	13
7.2	Switching 3D reconstruction PC on.....	13
8	Main parts.....	14
8.1	General view of X-ray system.....	14
8.2	General view of X-ray unit.....	15
8.3	Patient supports.....	16
8.4	Exposure switch.....	17
8.5	Emergency stop button.....	18
8.6	Control panel.....	19
9	Before exposure.....	25
9.1	Preparing X-ray system.....	25
9.1.1	Attaching patient supports.....	25
9.1.2	Preparing Planmeca Romexis.....	30
9.2	Preparing patient.....	30
10	2D panoramic exposure.....	32
10.1	Selecting imaging program.....	32
10.2	Patient positioning.....	32
10.3	Selecting patient size.....	37
10.4	Adjusting exposure values for current exposure.....	37
10.5	Taking a 2D exposure.....	38
11	3D exposure.....	42
11.1	3D dental programs.....	42
11.1.1	Preset volume sizes.....	42
11.2	Selecting imaging program.....	42
11.3	Patient positioning.....	43
11.4	Selecting patient's left or right side.....	45
11.5	Selecting patient size.....	47
11.6	Adjusting image volume position and size.....	47
11.7	Selecting image resolution and Ultra Low Dose (ULD).....	49
11.8	Adjusting exposure values for current exposure.....	50

11.9	Selecting Artefact Removal Algorithm (ARA) and patient movement correction (CALM).....	51
11.10	Taking scout views.....	52
11.11	Taking a 3D exposure.....	56
12	3D quality control.....	60
12.1	Tools required.....	60
12.2	Test procedure.....	61
12.3	Evaluating test results.....	64
13	Help messages.....	66
14	Error messages.....	69
15	Cleaning and disinfection.....	70
15.1	Patient supports, patient handles and touch screen.....	71
15.2	Other surfaces.....	73
16	Service.....	74
17	Disposal.....	75
18	Technical specifications.....	76
18.1	Technical data.....	76
18.2	Original manufacturer.....	78

The manufacturer, assembler and importer are responsible for the safety, reliability and performance of the unit only if:

- installation, calibration, modification and repairs are carried out by qualified authorised personnel
- electrical installations are carried out according to the appropriate requirements such as IEC 60364
- equipment is used according to the operating instructions.

Planmecca pursues a policy of continual product development. Although every effort is made to produce up-to-date product documentation this publication should not be regarded as an infallible guide to current specifications. We reserve the right to make changes without prior notice.

COPYRIGHT PLANMECCA

Publication Number 30005931 Revision 3

Release Date 6 July 2018

1 Introduction

The manual applies to the following X-ray units:

- Planmeca Viso G7

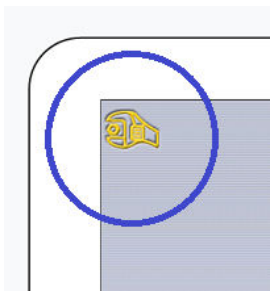

NOTE

This manual is valid for Planmeca Viso software version 1.1.1 or later. This software version is compatible with Planmeca Romexis software version 5.2.0.r or later. To check the software version of your X-ray unit, select **Settings > About > 4100 Component Information > Viso ProTouch SW Version**.

Make sure that you are fully acquainted with the appropriate radiation protection measures and these instructions before you use the X-ray unit. Note that your X-ray unit may not feature all the options described in these instructions.

These instructions include options that may not be available in all countries.

NOTE

The X-ray unit may be used by health care professionals only.

NOTE

Cone beam imaging should not be used for routine (or screening) examinations. The imaging examinations must be justified for each patient to demonstrate that the benefits outweigh the risks.

1.1 Device description

The Planmeca Viso X-ray unit uses cone beam computed tomography (CBCT) to produce three-dimensional (3D) images of the maxillofacial and ENT anatomies. Two-dimensional (2D) images are produced with the tomosynthesis method (panoramic imaging) as well as conventional 2D radiography (cephalometric imaging, 2D views).

In CBCT a cylindrical volume of data is captured in one imaging procedure. The data consists of several hundred sample images which are taken from different directions to cover a certain pre-programmed target area. These samples are used for 3D reconstruction (using a separate 3D reconstruction PC) that can be viewed in three dimensions using a separate workstation and the Planmeca Romexis software.

1.2 Intended use

Planmeca Viso is a system intended to produce two-dimensional (2D) and three-dimensional (3D) digital x-ray images as well as three-dimensional (3D) and four-dimensional (4D) optical images of the dento-maxillo-facial, cervical spine and ENT (Ear, Nose and Throat) regions at the direction of healthcare professionals as diagnostic support for pediatric and adult patients.

2 Associated documentation

The X-ray unit is supplied with the following manuals:

- User's Manual
- Installation Manual
- Technical Manual

These manuals are intended to be used in conjunction with the documentation for the Planmeca Romexis program. The Romexis package contains the following manuals:

- User's Manual
- Technical Manual

The original language of the manuals is English.

NOTE

The User's Manuals are available on Planmeca's website.

- For X-ray units, select [Material Bank > Manuals > Imaging](#).
- For software products, select [Material Bank > Manuals > Software](#).

3 Product registration

To register your X-ray unit on Planmeca's website:

1. Select Settings > About > 4300 Product Registration.
2. Do one of the following:
 - A QR (Quick Response) code is shown on the screen. If you have a QR code reader installed on your mobile device (e.g. smartphone), hold the device steady over the QR code. You will be directed to Planmeca's product registration page.
 - Go to Planmeca's product registration page at www.planmeca.com/register.
3. Select the green check mark button.
4. Follow the instructions on the registration page. Note that when you enter the X-ray unit serial number, you have to include any letters shown at the beginning of the number.



4 Symbols

4.1 Symbols on product labels



Fulfils the requirements of Directive 93/42/EEC.



SGS listing marking according to US and Canadian standards (ANSI/AAMI ES60601-1 and CAN/CSA C22.2 No. 60601- 1).



Date of manufacture (Standard ISO 7000).



Type B applied part (Standard IEC 60417).

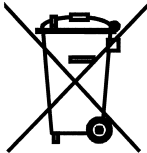

Separate collection for electrical and electronic equipment according to Directive 2002/96/EC (WEEE).



Refer to instruction manual/booklet (Standard ISO 7010).



Emergency stop (Standard IEC 60417)



Warning: Electricity (Standard ISO 7010).

To avoid risk of electric shock, this equipment must only be connected to a supply mains with protective earth.



Electrostatic sensitive device (Standard IEC 60417)



Warning, hot surface (Standard ISO 7010).



General warning (Standard ISO 7010).

5 Safety precautions



WARNING

The following safety precautions must be observed in order to avoid the risk of personal injury or damage to the X-ray unit.

CAUTION

FOR US USERS:

Federal law restricts this device to sale by or on the order of a health care professional.

CAUTION

This X-ray unit may be dangerous to both patient and operator unless safe exposure values are used and correct operating procedures are observed.

CAUTION

It is very important that the place where the X-ray unit is to be used and the position from which the user is to operate the X-ray unit are correctly shielded.

Since radiation safety requirements vary from country to country and state to state it is the responsibility of the user to ensure that all local safety requirements are met.

CAUTION

The patient positioning lights are laser lights. Do not stare into the laser beam.

CAUTION

If an exposure is interrupted (e.g. exposure button is released or emergency stop button activated), the patient must be guided away from the X-ray unit before the C-arm is moved.

CAUTION

Do not connect items which are not specified as part of the system.

CAUTION

Do not touch an electrical connector and the patient at the same time.

CAUTION

If the X-ray unit shows any signs of oil leakage, switch the X-ray unit off and contact your service technician for help.

CAUTION

Do not use the X-ray unit in an oxygen rich environment or in the presence of flammable anesthetics.

CAUTION

Never use a defective or damaged X-ray system. Contact your service technician for help.

CAUTION

Do not modify the X-ray unit. The X-ray unit must be serviced by qualified personnel only.

CAUTION

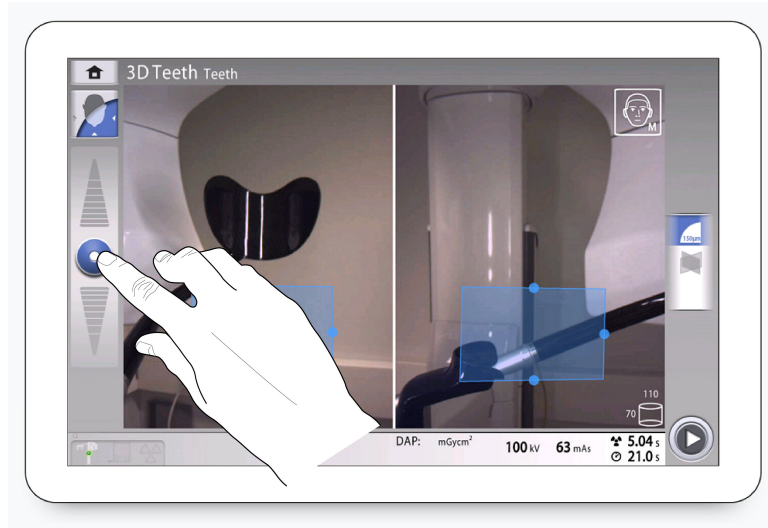

Be careful that the X-ray unit does not hit the ceiling when you move the X-ray unit up. The maximum height can be adjusted to suit offices with a low ceiling. Contact your service technician for help.

CAUTION

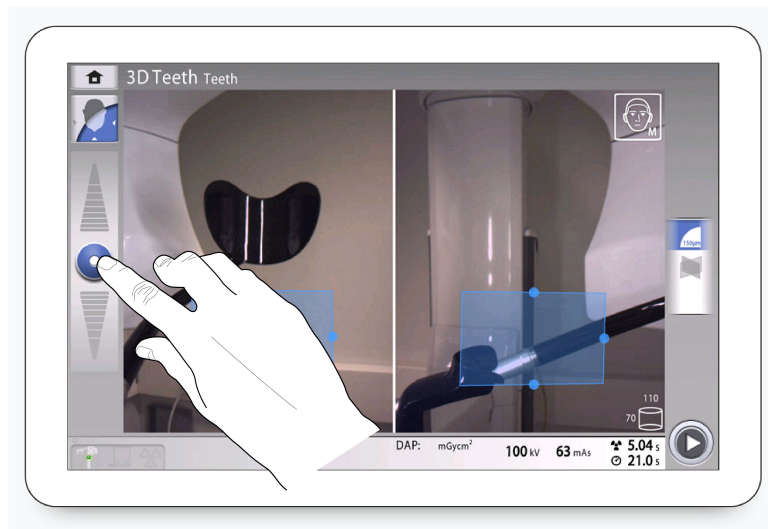

Make sure that there is no object under the X-ray unit when you move the X-ray unit down. If something is in danger of becoming trapped, release the height adjusting slider immediately to stop the movement. Clear any obstruction before moving the X-ray unit again.

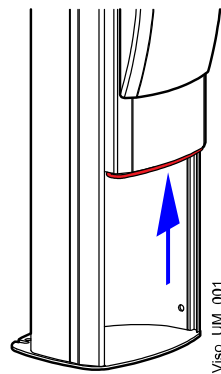
NOTE

The column movement stops automatically if the emergency stop plate at the bottom is pressed upward. Clear any obstruction before moving the X-ray unit again.

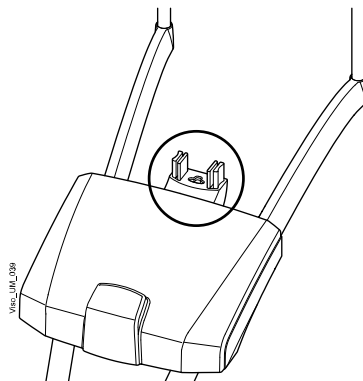
NOTE

The adapter base is magnetically attached to the patient support base. This is a safety feature that ensures that the patient's head cannot get stuck if the patient faints or begins to fall when they are positioned in the X-ray unit.

NOTE

When positioning seated patients (e.g. in a wheelchair) always first move the X-ray unit down before you position the patient in the X-ray unit.

NOTE

Cone beam imaging should not be used for routine (or screening) examinations. The imaging examinations must be justified for each patient to demonstrate that the benefits outweigh the risks.

NOTE

When it is likely that evaluation of soft tissues will be required as part of the patient's radiological assessment, conventional CT or MR medical imaging should be used rather than CBCT.

NOTE

Before taking an exposure, ask any female patient of childbearing age whether she might be pregnant. The X-ray unit is not intended for use on pregnant women.

NOTE

FOR CANADIAN USERS:

All patients must be provided with a shielded apron for gonad protection and a thyroid shield. The use of a thyroid shield is especially important in children. The shielded apron and thyroid shield should have a lead equivalence of at least 0.25 mm on both sides (front and back of the patient).

NOTE

If the X-ray unit has been stored at temperatures under +10°C for more than a few hours, time must be allowed for the unit to reach room temperature before turning it on.

NOTE

Ensure efficient air conditioning in the X-ray room. It is recommended to keep the room temperature between +20°C and +25°C at all times.

NOTE

If exposures are taken in rapid succession, the X-ray tube may overheat and a cooling time will flash on the control panel. The cooling time indicates the delay before the next exposure can be taken.

NOTE

If the X-ray system is not connected to an Uninterruptible Power Supply (UPS), switch the X-ray unit off and disconnect the PCs from the mains during lightning storms.

NOTE

FOR US & CANADIAN USERS:



The laser lights are class II laser products (21 CFR § 1040.10).

NOTE

FOR EUROPEAN USERS:



The laser lights are class 1 laser products (Standard IEC / EN 60825-1: 2007).

NOTE

EMC requirements have to be considered, and the equipment must be installed and put into service according to the specific EMC information provided in the accompanying documents.

NOTE

Portable and mobile RF communications equipment can affect the X-ray unit.

NOTE

External equipment intended for connection to signal input, signal output or other connectors, shall comply with relevant IEC standard (e.g. IEC 60950 for IT equipment and the IEC 60601 series for medical electrical equipment). In addition, all such combinations - systems - shall comply with the standard IEC 60601-1, Safety requirements for medical electrical systems. Equipment not complying to IEC 60601 shall be kept outside the patient area (more than 2m (79 in.) from the X-ray unit). Any person who connects external equipment to signal input, signal output or other connectors has formed a system and is therefore responsible for the system to comply with the requirements of IEC 60601-1. If in doubt, contact your service technician or local representative for help.

NOTE

Contact your service technician if you notice a decrease in image quality.

NOTE

If you take an exposure but the image does not appear in the Planmeca Romexis program, you can import the image manually into Romexis. Refer to the Planmeca Romexis User's Manual for details.

NOTE

Do not handle liquids near or on the X-ray unit.

NOTE

Never place or hang any objects on any part of the X-ray unit.

NOTE

Make sure that neither you nor your patient can get caught or hooked up on any part of the X-ray unit. Keep loose items of clothing, hair and jewellery tucked away safely.

NOTE

Do not touch the arm structures when the X-ray unit is moving.

NOTE

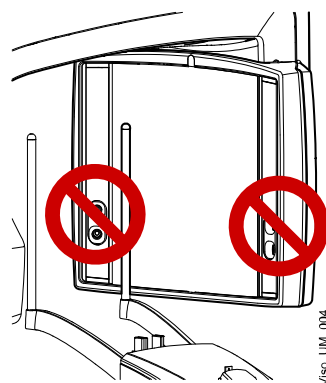

Do not touch the glass windows of the sensor. Fingerprints or other stains on the glass surface destroy image quality.

6 Pediatric use

6.1 Introduction

Special care should be exercised when imaging patients outside the typical adult size range, especially smaller pediatric patients whose size does not overlap the adult size range (typically children under the age of 13).

Exposure to ionising radiation is of particular concern in pediatric patients because:

1. For certain organs and tumor types, younger patients are more radiosensitive than adults (i.e. the cancer risk per unit dose of ionising radiation is higher for younger patients).
2. Use of equipment and exposure settings designed for adults of average size can result in excessive and unnecessary radiation exposure of smaller patients.
3. Younger patients have a longer expected lifetime over which the effects of radiation exposure may manifest as cancer.

To help reduce the risk of excessive radiation exposure, you should follow the ALARA (As Low As Reasonably Achievable) principle and seek to reduce radiation dose to only the amount necessary to obtain images that are adequate clinically.

6.2 References for pediatric dose optimisation

The following resources provide information about pediatric imaging radiation safety and / or radiation safety for cone beam computed tomography devices:

- Pediatric X-ray Imaging (<http://www.fda.gov/Radiation-EmittingProducts/RadiationEmittingProductsandProcedures/ucm298899.htm>)
- Medical X-ray Imaging (<http://www.fda.gov/Radiation-EmittingProducts/RadiationEmittingProductsandProcedures/MedicalImaging/MedicalX-Rays/default.htm>)

6.3 Device specific features and instructions

The X-ray unit provides the following specific design features and instructions that enable safer use with pediatric patients:

Design feature important to pediatric imaging (standard or optional)	Refer to section
Head support that can be adjusted for pediatric patients (standard)	"Patient positioning" on page 32 (2D panoramic exposure) and "Patient positioning" on page 43 (3D exposure)
Preset control settings which clearly specify the intended size range (standard)	"Selecting patient size" on page 37 (2D panoramic exposure) and "Selecting patient size" on page 47 (3D exposure)
Display and recording of patient dose or dose index and ability to record other patient information, e.g. age (standard)	"Control panel" on page 19 (Checking DAP values) Planmeca Romexis User's Manual (Entering date of birth and Generating X-ray log book)
ULD (Ultra Low Dose) setting (optional)	"Selecting image resolution and Ultra Low Dose (ULD)" on page 49

Design feature important to pediatric imaging (standard or optional)	Refer to section
CALM (Correction Algorithm for Latent Movement) setting (optional)	"Selecting Artefact Removal Algorithm (ARA) and patient movement correction (CALM)" on page 51
Scout views (standard)	"Taking scout views" on page 52
User's manuals that consider the balance of radiation exposure and image quality (standard)	"Introduction" on page 11, "Adjusting exposure values for current exposure" on page 37 (2D panoramic exposure) and "Adjusting exposure values for current exposure" on page 50 (3D exposure)

Testing information	Refer to section
Estimated patient dosimetry covering pediatric size ranges (standard)	"Control panel" on page 19 (Checking DAP values) Planmeca Romexis User's Manual (Generating X-ray log book)
Quality control instructions including tests to ensure proper operation across a broad patient size range (standard)	"3D quality control" on page 60

7 Switching X-ray system on

NOTE

To prolong the lifetime of your X-ray system, always switch the X-ray system off when it is not in active use.

7.1 Switching X-ray unit on

The on / off switch is located on the underside of the column top.

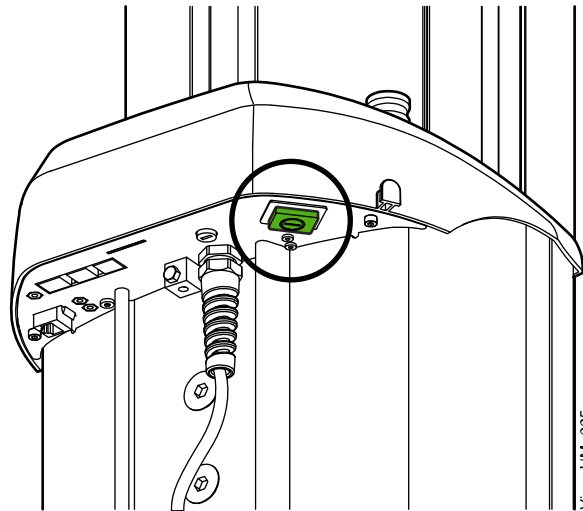

7.2 Switching 3D reconstruction PC on

The on / off switch is located at the top of the computer.



8 Main parts

8.1 General view of X-ray system

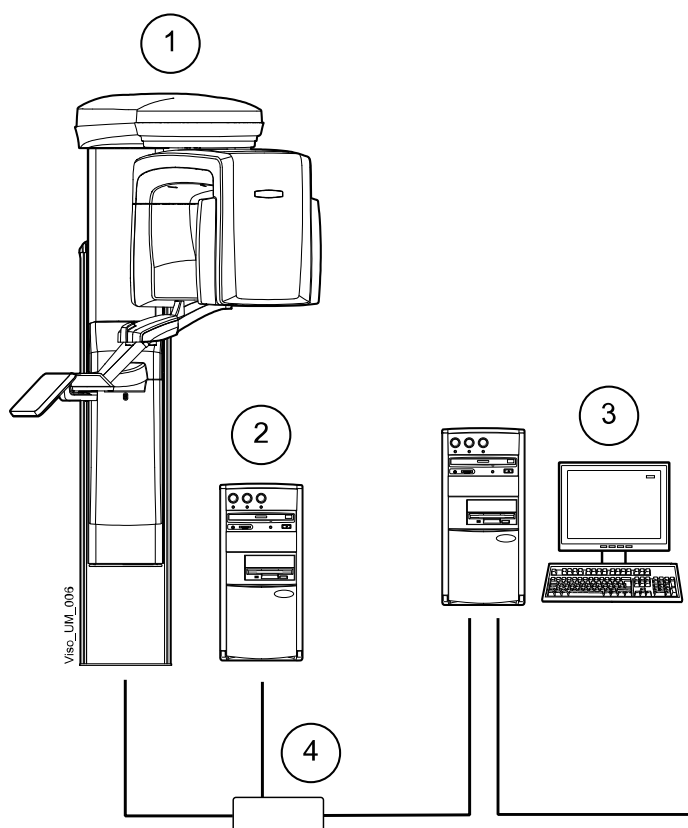

- 1 X-ray unit
- 2 3D reconstruction PC
- 3 Planmeca Romexis program
- 4 Ethernet switch

8.2 General view of X-ray unit

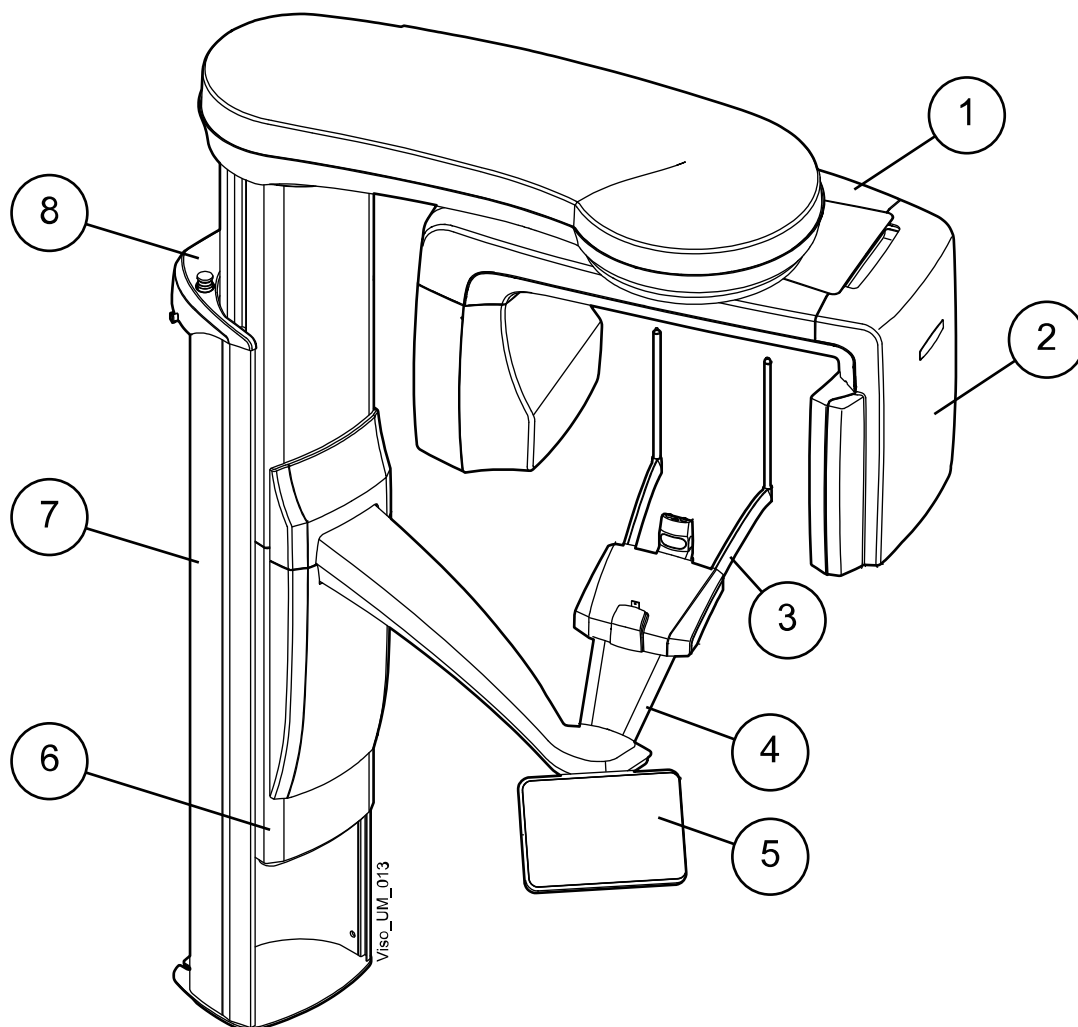

- 1 C-arm
- 2 Sensor with digital cameras
- 3 Patient supports (see section "Patient supports" on page 16)
- 4 Patient handles
- 5 Touch screen (see section "Control panel" on page 19)
- 6 Moving column
- 7 Stationary column
- 8 Emergency stop button (see section "Emergency stop button" on page 18)

8.3 Patient supports

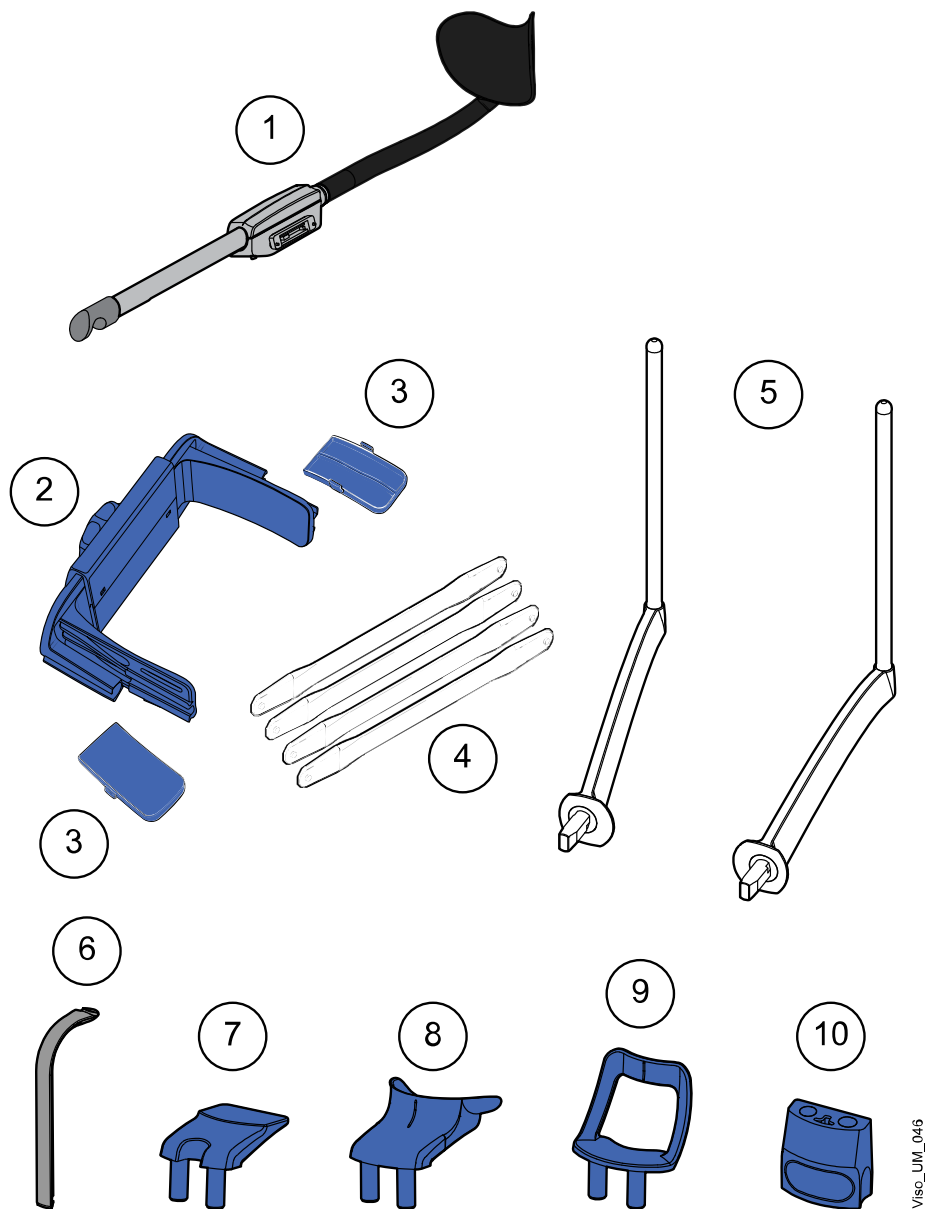

- 1 Rear head support
- 2 Top head support
- 3 Temple pads for children
- 4 Fastening straps
- 5 Support bars
- 6 Bite piece (for panoramic exposures)
- 7 Chin rest (for panoramic exposures)
- 8 Chin cup
- 9 Chin support (for panoramic exposures)
- 10 Adapter

Viso_LUM_046

8.4 Exposure switch

The exposure switch can be mounted on the wall, or it can be hung from the hook provided on the column top if a protected area is within reach.

A green light flashes on the exposure button when the X-ray system is getting ready for an exposure. The green light stops flashing and stays on continuously when the X-ray system is ready for an exposure.

During exposure a yellow radiation warning light illuminates on the exposure switch. It indicates that the X-ray unit is generating radiation.

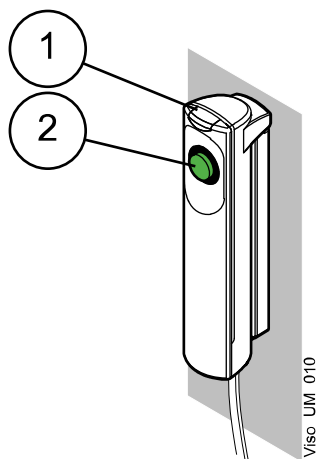

- 1 Exposure switch
- 2 Exposure button

8.5 Emergency stop button

Press the emergency stop button to stop the X-ray unit operating in an emergency. All movements of the X-ray unit will be blocked and no radiation will be generated.

A help message will appear on the control panel. Guide the patient away from the X-ray unit. Then release the emergency stop button. The X-ray unit will automatically restart.

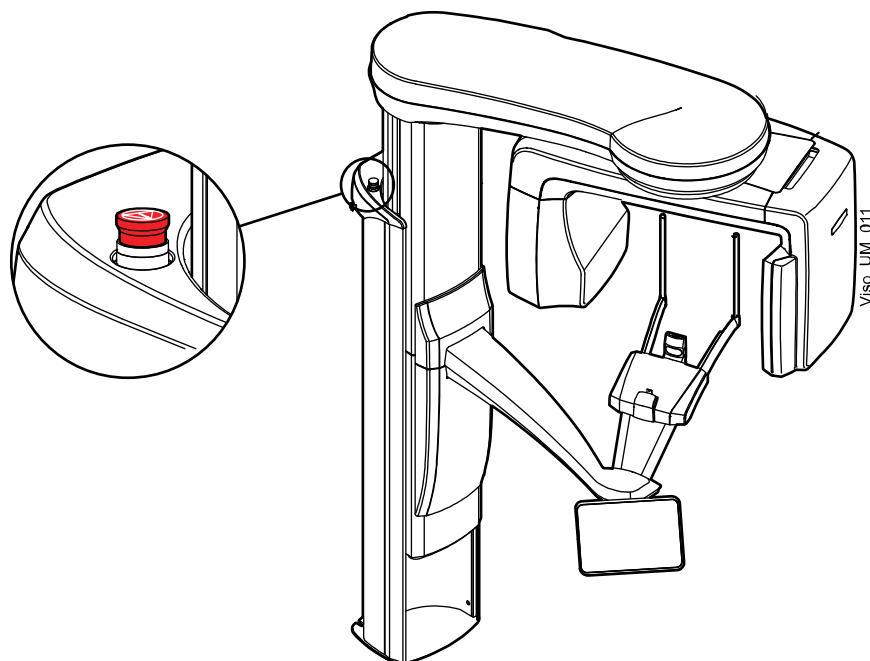

8.6 Control panel

You can use the control panel from

1. the touch screen that is part of the X-ray unit and
2. the virtual control panel that is integrated into the Planmeca Romexis program. The virtual control panel is shown on the computer screen when you have selected the patient and the exposure mode in Planmeca Romexis.

The two control panels are synchronized, and you can use either or both of them. Note, however, that the height adjusting slider cannot be used on the virtual control panel (2).

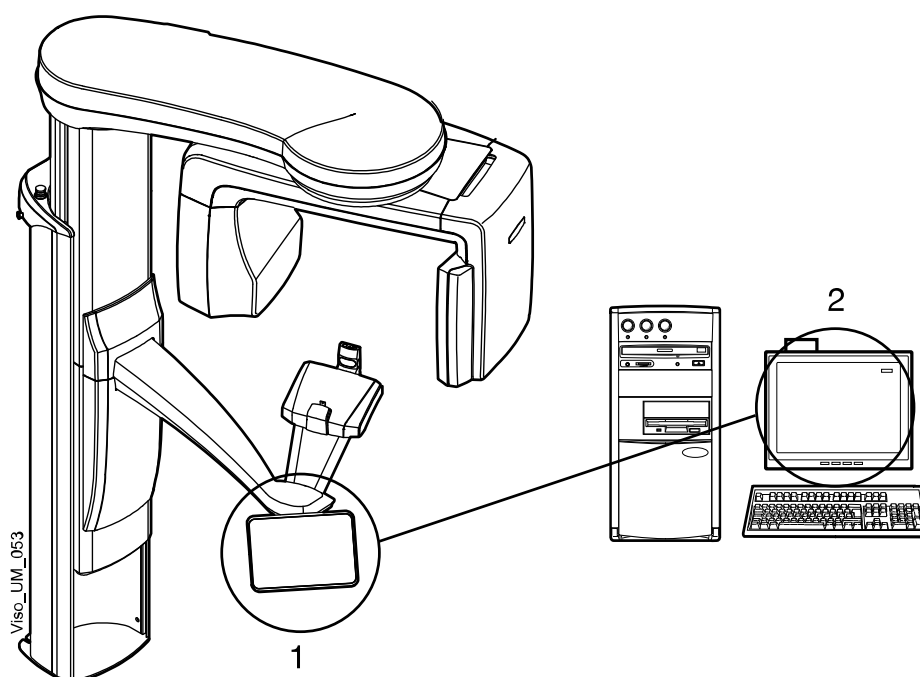

NOTE

The options shown on the screen depend on the X-ray unit configuration. The views and values shown in this manual are only examples.

NOTE

The X-ray unit can be upgraded with new programs and features. Contact your dealer for further information.

NOTE

Never allow patients to touch the screen when they are positioned in the X-ray unit. Touching the screen during exposure will stop the imaging process.

Making selections

- To make a selection on the touch screen, simply touch a button or a field with your finger or a soft stylus.

You hear an audible signal when you make a selection.

NOTE

Do not use sharp objects to operate the touch screen.

- To make a selection on the virtual control panel in the Planmeca Romexis program, simply click your mouse on the function that you wish to use.

The selected option is highlighted. To deselect an option, select the button or field again (or select another option if available).

Main screen

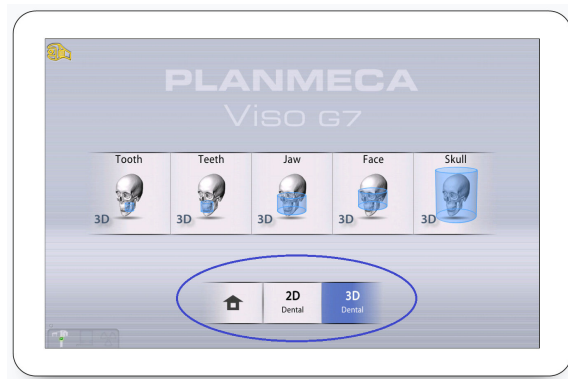

The main screen shows the name and the imaging programs of the X-ray unit. You can use the buttons at the bottom of the main screen to change the appearance of the main view.

Home button

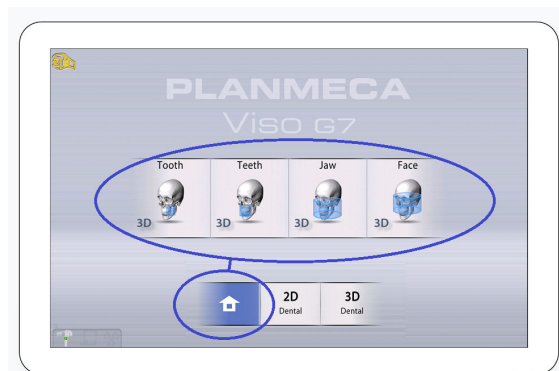

To view up to five most recently used programs, select the home button. The most recently used program is shown first. This is the default view of the main screen.

Program group buttons

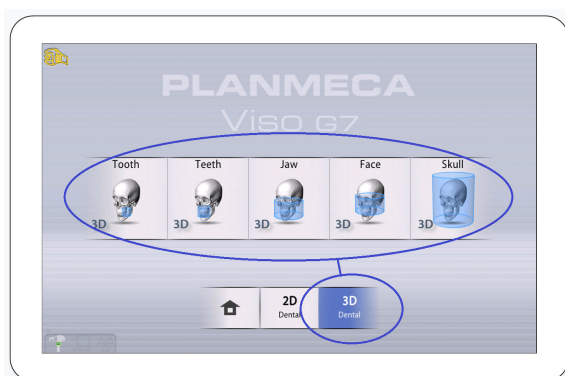

To view all the programs that are available for a program group, select the program group button.

Accept button



To accept a selection, select the green check mark button.

Cancel button



To cancel a selection and close a pop-up window, select the red cross button.

Home button

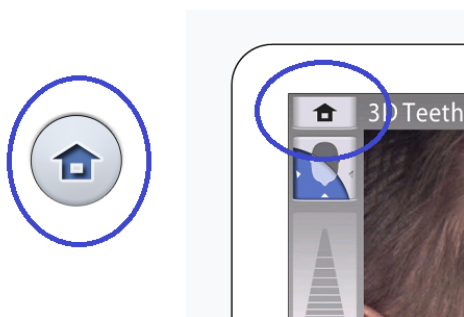

To go to the home screen from another screen, select the home button.

Scrolling lists

To scroll a list up or down, slide your finger on the screen.

Height adjusting slider (touch screen only)

Use this slider on the touch screen to move the X-ray unit up or down.

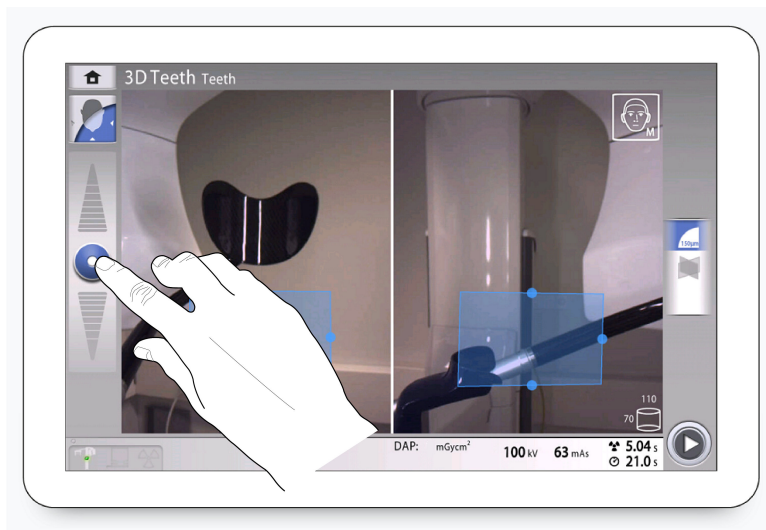

- Move the slider up to move the X-ray unit up.
- Move the slider down to move the X-ray unit down.

The X-ray unit moves slowly at first, then faster.

About circle symbol

You see a spinning circle on the screen when the C-arm moves to a new position. The length of the blue section indicates the length of the movement: the longer the section is, the more the C-arm will move. The circle disappears when the C-arm has reached the new position.

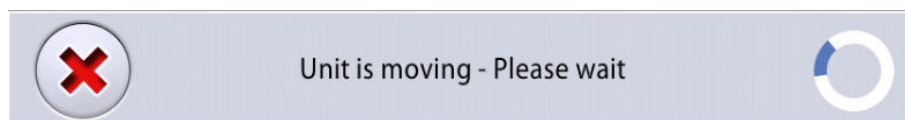

Checking exposure values

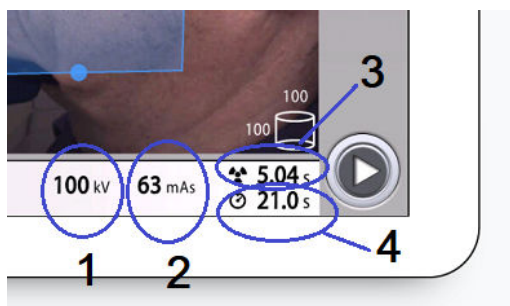

- 1 kV = kilovolt setting
- 2 mAs = milliamperere second setting
- 3 Exposure time = Effective exposure time in seconds i.e. the time that the patient receives radiation
- 4 Scan time = Total scan time in seconds i.e. the time that you press the exposure button

Checking DAP value

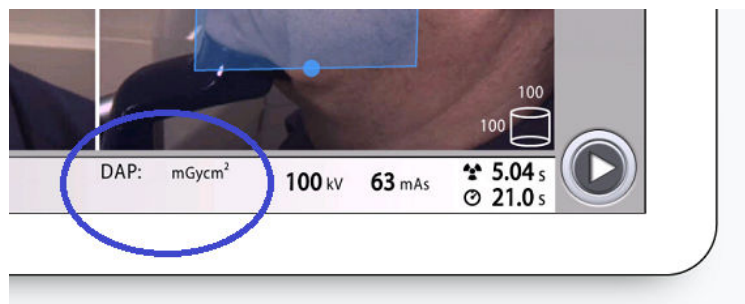

DAP = Dose Area Product

The DAP value shown on the screen before you take an exposure is an estimate. The actual DAP value is shown after the exposure.

Changing settings

To change a setting, select the settings symbol on the main screen. This takes you to the settings menu where you can adjust the settings of the X-ray unit.

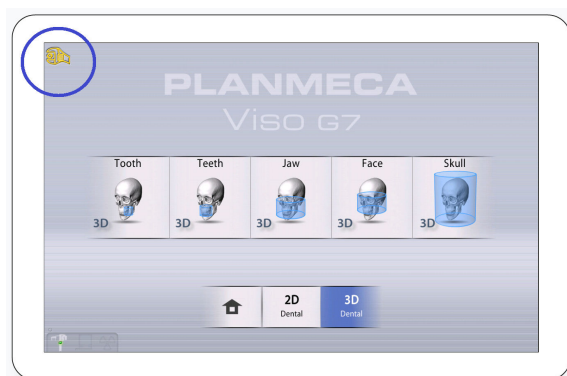

- **Selecting demo mode**

You can switch the demo mode on if you wish to practice or demonstrate the functions of the X-ray unit without radiation and PC connection (Settings > User > 1300 Operational Settings > 1310 Mode > 1311 Demo Mode).

You see these symbols in the bottom left corner of the screen when the demo mode is switched on. Additionally, a prohibition sign is shown on the top of the radiation symbol when you press the exposure button.

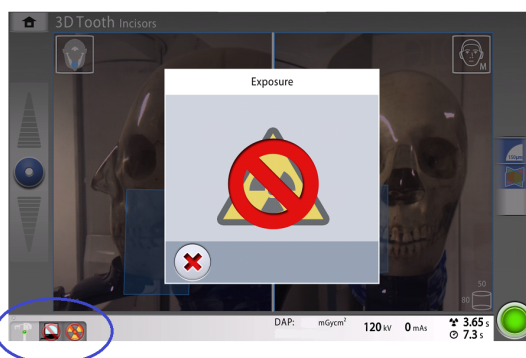

Closing virtual control panel

Click on this cross if you need to close the virtual control panel on the computer screen.

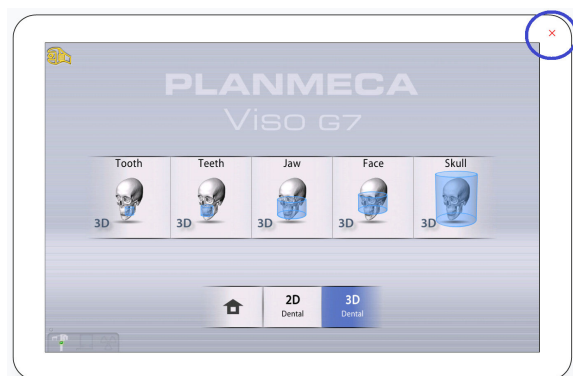

9 Before exposure

9.1 Preparing X-ray system

9.1.1 Attaching patient supports

9.1.1.1 Attaching chin supports for 2D panoramic exposures

Attach these supports to the adapter.

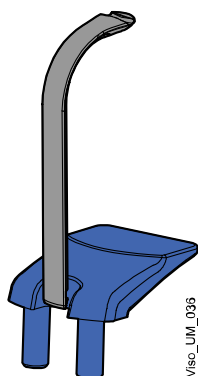

- You can use these supports for edentulous patients or for patients who are unable to bite.

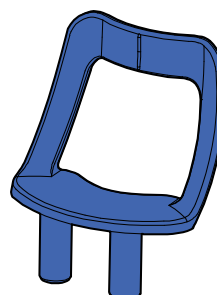
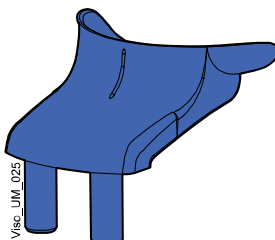

9.1.1.2 Attaching chin supports for 3D exposures

Attach this support to the adapter.

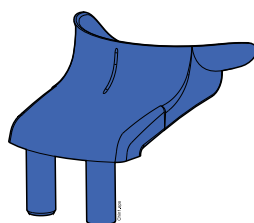

9.1.1.3 Attaching rear head support

First attach the rear head support to the connector on the patient support base and then close the locking lever at the back.

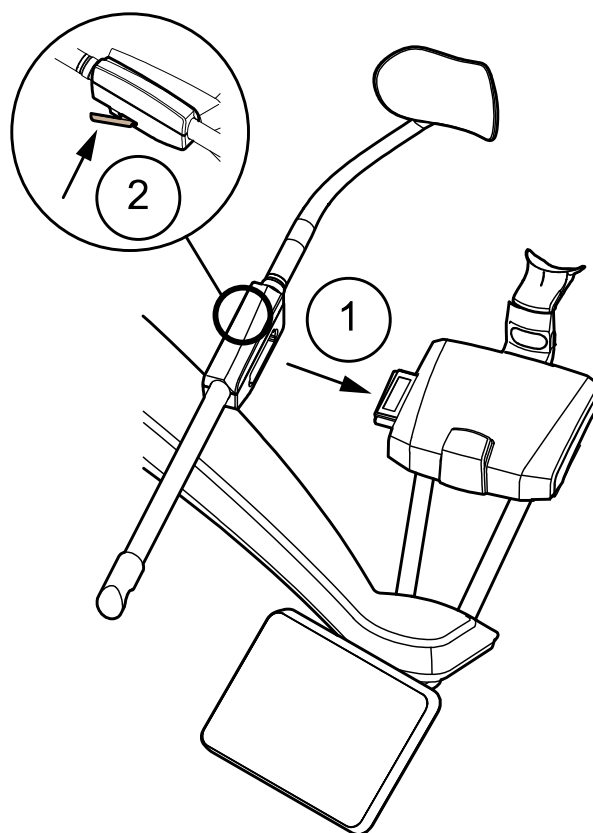

Viso_UIM_044

- To remove the rear head support, first release the locking lever and then pull the head support out.

9.1.1.4 Attaching support bars

First insert the support bar into the hole at the back of the patient support base and then lock it in position by turning it outwards.

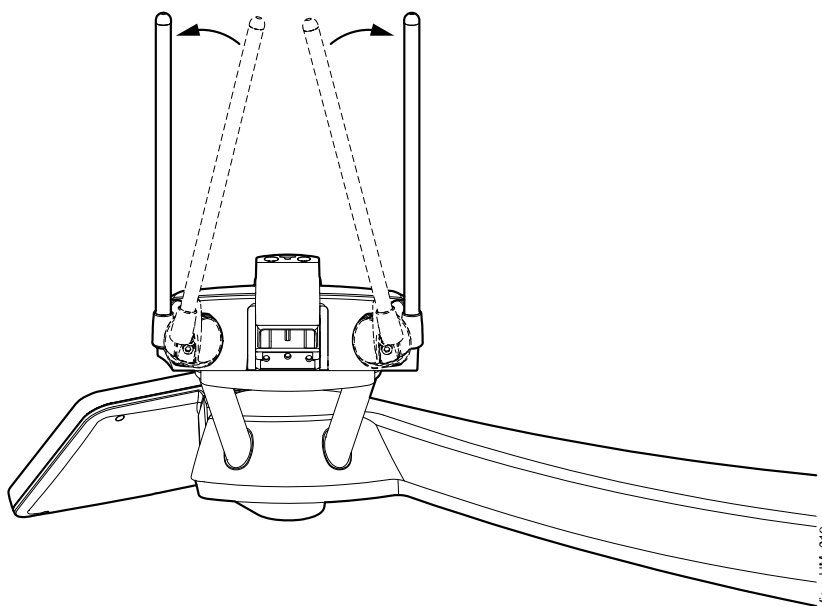

NOTE

Ensure that you insert the support bars the right way round. The wider sides of the round end parts have to be on the inside as shown.

- To remove the support bar, first turn it inwards and then pull it out.

9.1.1.5 Attaching top head support

Slide the top head support onto the support bars.

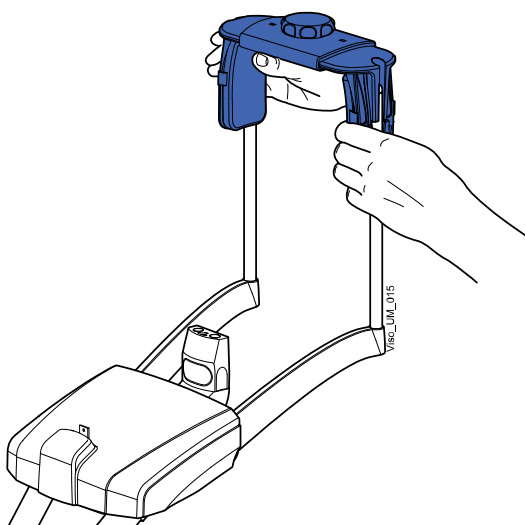

- You can turn the adjusting knob to adjust the head support to suit the size of the patient's head.

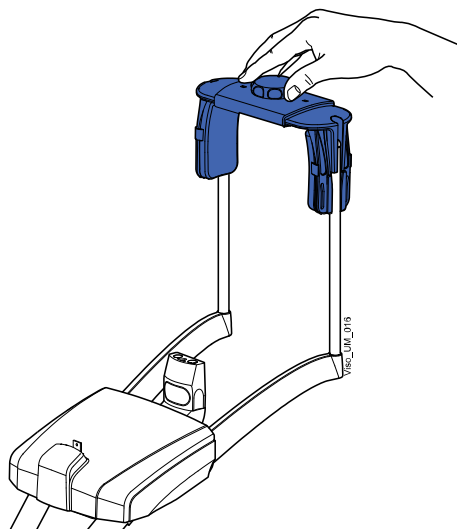

- You can use temple pads if you take exposures of children or patients with a small head. Slide the temple pads onto the head support as shown. Ensure that you slide the temple pads as far up as they will go.

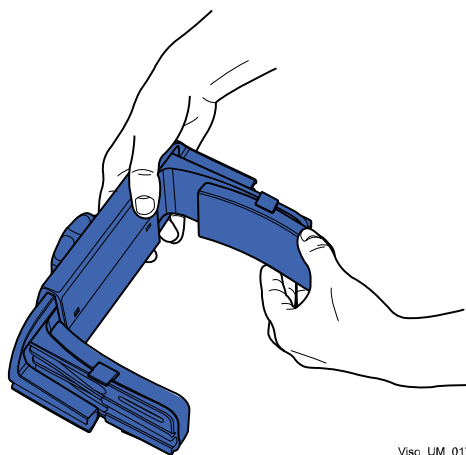

NOTE

Use temple pads on both sides (not on one side only).

- You can use fastening straps for additional head support if needed. Attach one strap in front of the forehead and two at the back of the head as shown.

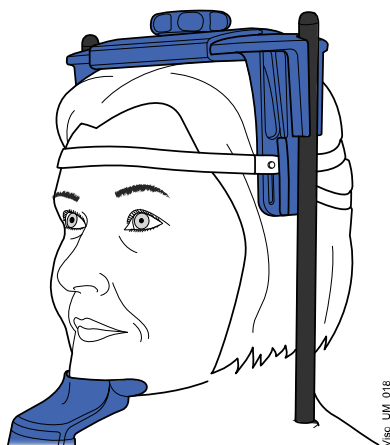

NOTE

Be careful when you handle the straps. Do not let the straps hit the patient in the eye or face.

NOTE

Do not overstretch the straps. The straps lose their elasticity if you pull them more than 50 mm (2 in.). Straps with a free length (i.e. when they are not stretched) of over 255 mm (10 in.) do not support the patient's head firmly.

9.1.2 Preparing Planmeca Romexis

1. Select the patient.

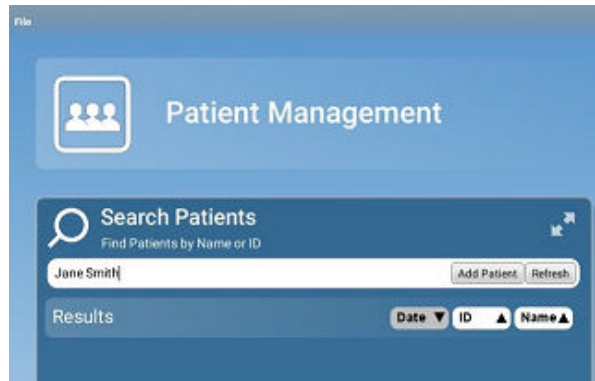

2. Depending on the exposure you are taking, select the
 - 2D panoramic exposure

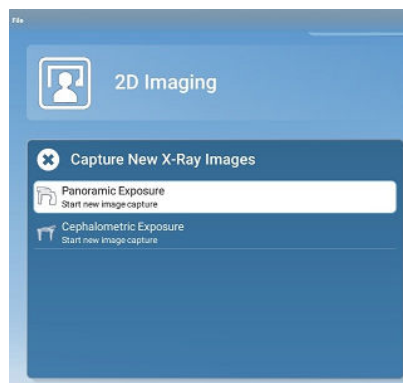

or

- 3D exposure



Refer to the Planmeca Romexis User's Manual for details on Romexis functions.

9.2 Preparing patient

Ask the patient to remove any spectacles, hearing aids, dentures, hairpins, and personal jewellery such as earrings, necklaces and piercings as these can produce shadows or reflections in the image. The patient should also remove any loose items of clothing (e.g. scarf, tie) that might get caught in the arm structures of the X-ray unit.

NOTE

High contrast objects, such as gold teeth or amalgam, may cause artefacts in the image.

Place a protective lead apron over the patient's back if required.

10 2D panoramic exposure

10.1 Selecting imaging program

Select the panoramic program (2D Dental > Panoramic).



- The sensor moves to the back if it is not already there. You see this message.

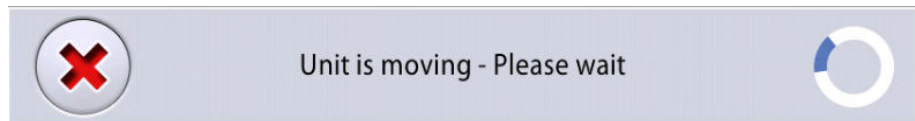

10.2 Patient positioning

1. Guide the patient to the X-ray unit when you see this message.

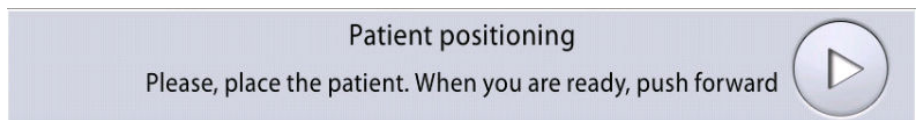

- The patient can sit or stand during the exposure.

NOTE

We recommend that you image patients with poor health in a sitting position.

- Use the height adjusting slider on the touch screen to move the X-ray unit up or down until the chin rest is approximately level with the patient's lower jaw.

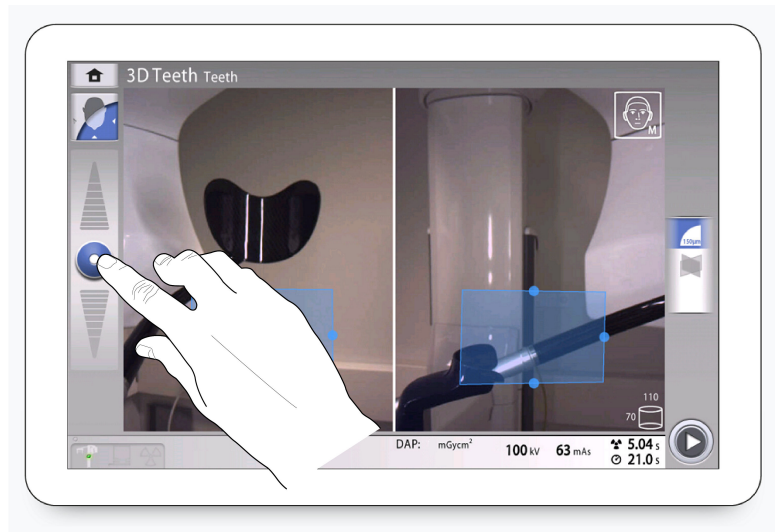

- Ask the patient to step forward, grasp the patient handles, stretch and straighten their back and neck, and bite the bite piece. The upper and lower incisors must be in the groove in the bite piece.

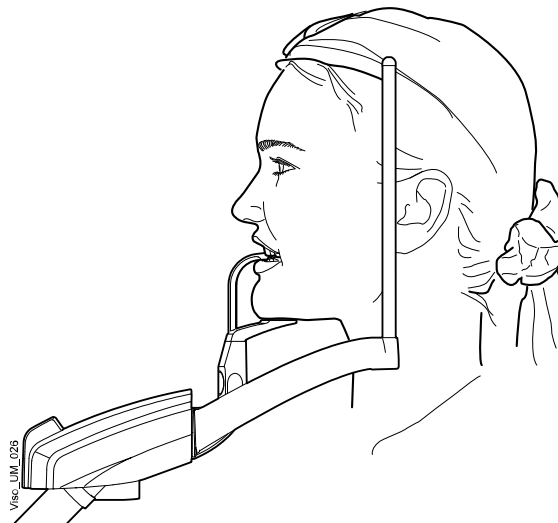

NOTE



If you are using the chin support, position the patient so that the chin touches the top bar as shown.

NOTE

If you are using the chin support or chin cup, use for example a cotton roll between the patient's teeth to ensure that the upper and lower incisors do not make contact.

4. Position the patient's head so that the patient's midsagittal plane coincides with the midsagittal plane laser light.
 - The midsagittal plane laser light is shown in the middle of the patient's face.

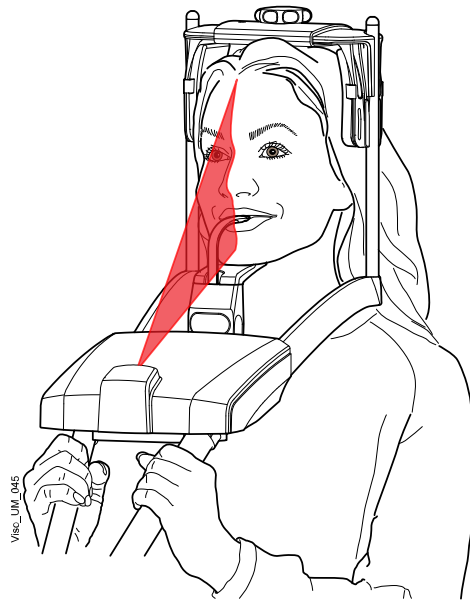

5. If you are using the rear head support:
 - You can slide the rear head support up or down for optimal support of the patient's head.

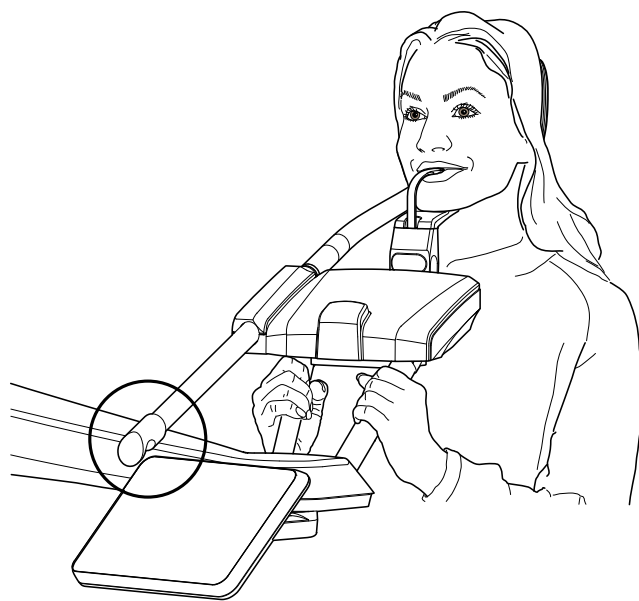

6. If you are using the top head support:

- You can adjust the head support by turning the adjusting knob at the top.

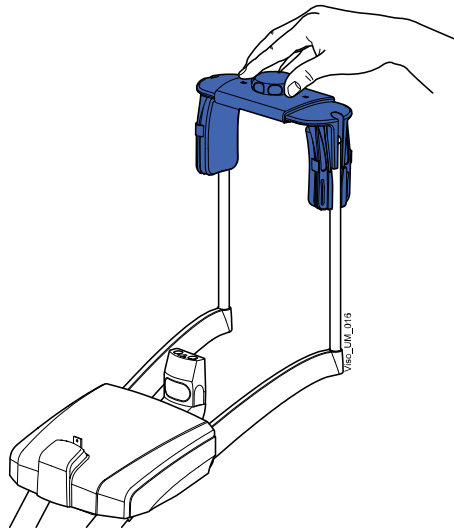

7. Select the forward button.

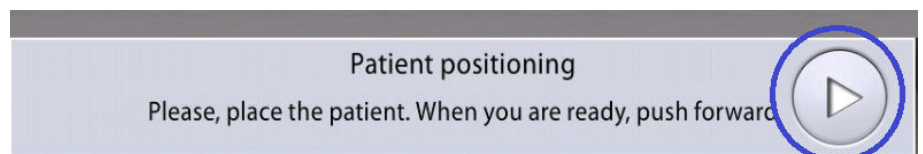

- The sensor moves to the front. You see this message.

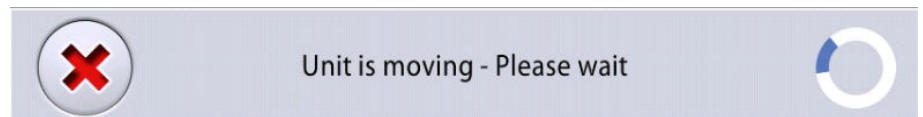

The sensor contains digital cameras which stream live video of the patient's head.

8. You see two camera images of the patient's head on the control panel: a front view and a side view. The preset position of the panoramic image layer is shown with a blue area in both views.

Carefully position the patient's Frankfort plane so that it is parallel to the Frankfort plane reference line:

- Use the height adjusting slider on the touch screen to adjust the tilt of the patient's head. The patient's back and neck must be straight.

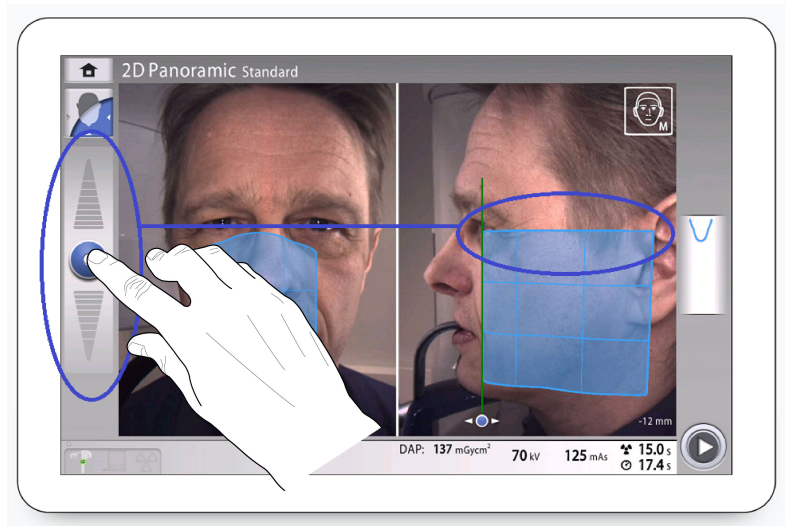

9. Position the apices of the patient's upper central incisors within the image layer of the X-ray unit:

- A virtual layer light is shown with a green line on the screen. Use your mouse cursor (virtual control panel) or finger (touch screen) to move the blue area forwards or backwards so that the green line is positioned between the patient's second incisor and the canine.

The selected position is shown in the bottom right corner (e.g. 0 mm).

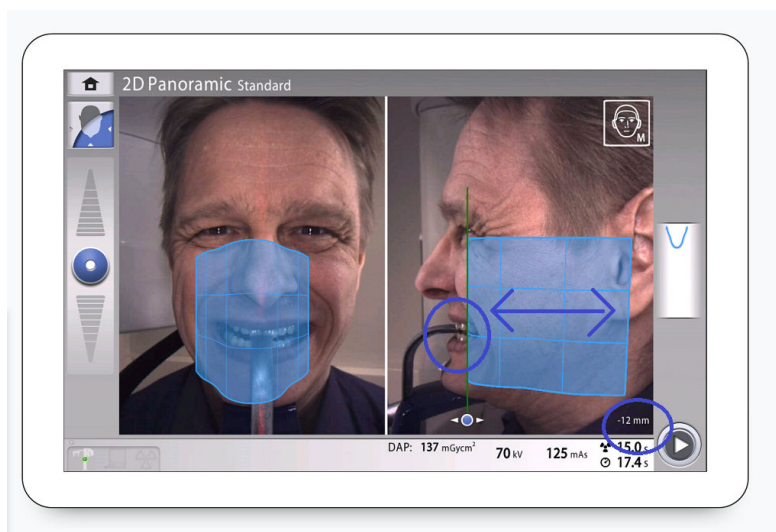

10. Check that the midsagittal plane light and the Frankfort plane reference line are still correctly positioned. Reposition them if necessary.

10.3 Selecting patient size

Use this button to select the patient size:

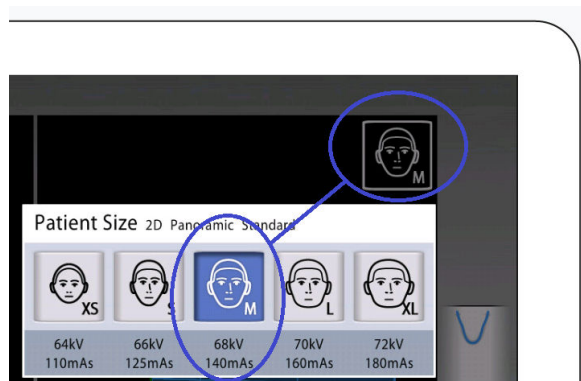

- XS = Child
- S = Small adult
- M = Medium-sized adult
- L = Large adult
- XL = Extra large adult

The preset exposure values are shown below the patient sizes.

NOTE

Selecting child patient (XS) will automatically reduce the exposure area.

NOTE

The exposure values will automatically change according to the selected patient size.

10.4 Adjusting exposure values for current exposure

The exposure values have been preset at the factory for each patient size. The preset exposure values are average values and they are only meant to guide the user.

NOTE

Always try to minimize the radiation dose to the patient.

The preset exposure values are shown in the following table.

Factory presets for panoramic exposures

PATIENT SIZE	kV VALUE	mAs VALUE
Child (XS)	64	110
Small adult (S)	66	125
Medium-sized adult (M)	68	140
Large adult (L)	70	160
Extra large adult (XL)	72	180

If you need to adjust the preset exposure values for this exposure:

1. Select this field to open a pop-up window.
2. Use the minus or plus signs to set the exposure values you wish to use. To improve the image contrast, reduce the kV value. To reduce the radiation dose, reduce the mAs value.
3. Select the green check mark button.



10.5 Taking a 2D exposure

NOTE

Make sure that you have selected the correct patient in the Planmeca Romexis program.

1. Select the forward button.



- Green lights flash on the control panel and exposure button when the X-ray system is getting ready for an exposure. You see this message.

NOTE

Move to a protected area.

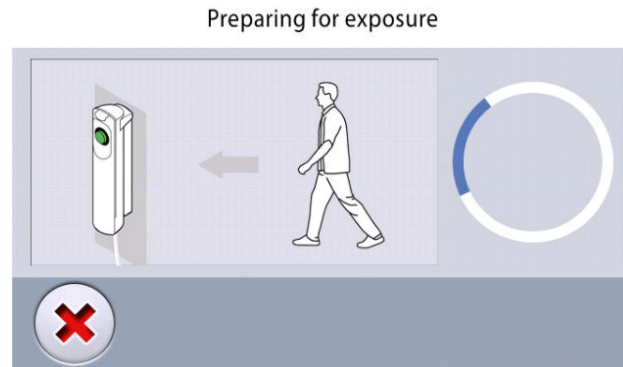

- The green lights stop flashing and stay on continuously when the X-ray system is ready for an exposure. You see this message.



- Ask the patient to swallow, place their tongue flat against the roof of the mouth and stay as still as possible.
- Press and hold down the exposure button for the duration of the exposure.

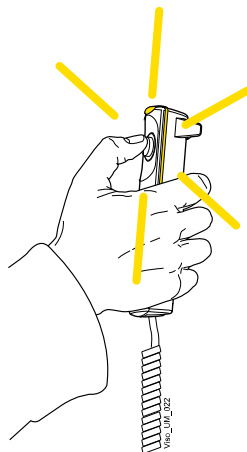

The C-arm moves around the patient's head.

- During exposure yellow radiation warning lights illuminate on the exposure switch and on the control panel. Additionally, you hear a radiation warning tone and see a radiation warning symbol on the control panel.
- You can follow the imaging process on the virtual control panel.

NOTE

Do not release the exposure button before the end of the exposure.

NOTE

Maintain audio and visual contact with the patient and X-ray unit during exposure. If the C-arm stops moving during exposure, or moves in an erratic way, release the exposure button immediately.

4. You see this message on the touch screen.
 - Select this button if you want to move the sensor to the back so that the patient can leave the X-ray unit.

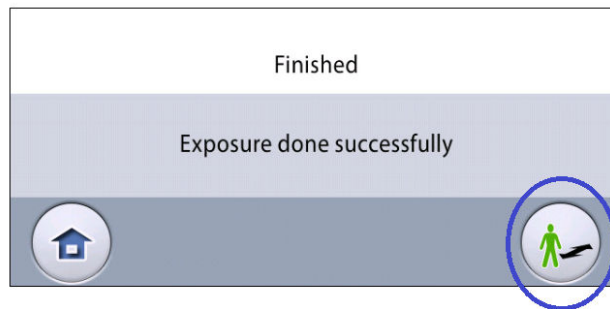

- Select this button if you want to go to the home screen.

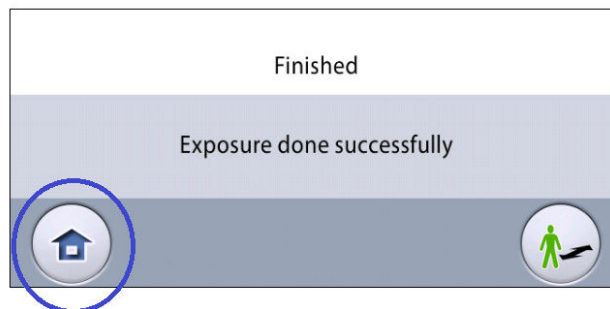

5. Release the patient from the head support.
6. Guide the patient away from the X-ray unit.

7. The image is shown on the computer screen.



11 3D exposure

11.1 3D dental programs

11.1.1 Preset volume sizes

PROGRAM	Ø50 mm	Ø100 mm	Ø140 mm	Ø160 mm	Ø260 mm
Tooth	Ø50 x H50 mm				
Teeth		Ø100 x H100 mm			
Jaw			Ø140 x H100 mm		
Face				Ø160 x H160 mm	
Skull					Ø260 x H300 mm*

* = Two vertical image volumes

11.2 Selecting imaging program

Select the 3D program you wish to use (e.g. 3D Dental > 3D Teeth).

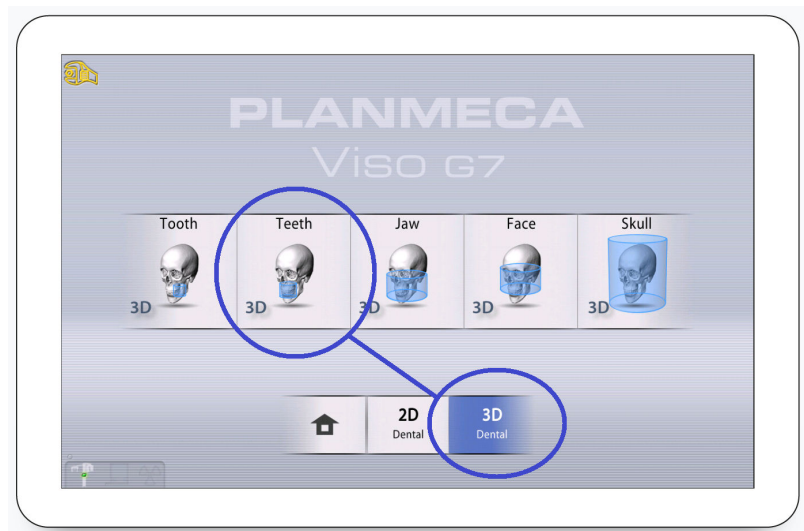

- The sensor moves to the back if it is not already there. You see this message.

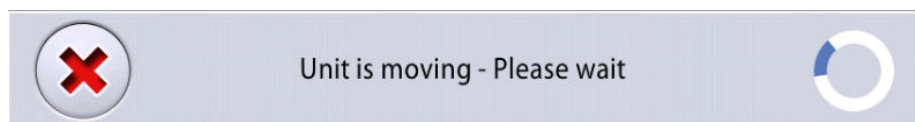

11.3 Patient positioning

1. Guide the patient to the X-ray unit when you see this message.

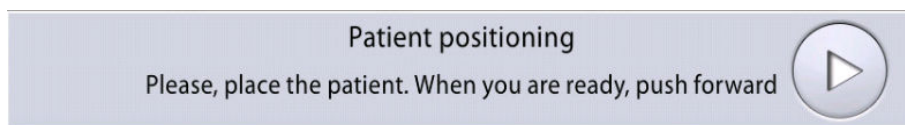

- The patient can sit or stand during the exposure.

NOTE

We recommend that you image patients with poor health in a sitting position.

2. Use the height adjusting slider on the touch screen to move the X-ray unit up or down until the chin cup is approximately level with the patient's lower jaw.

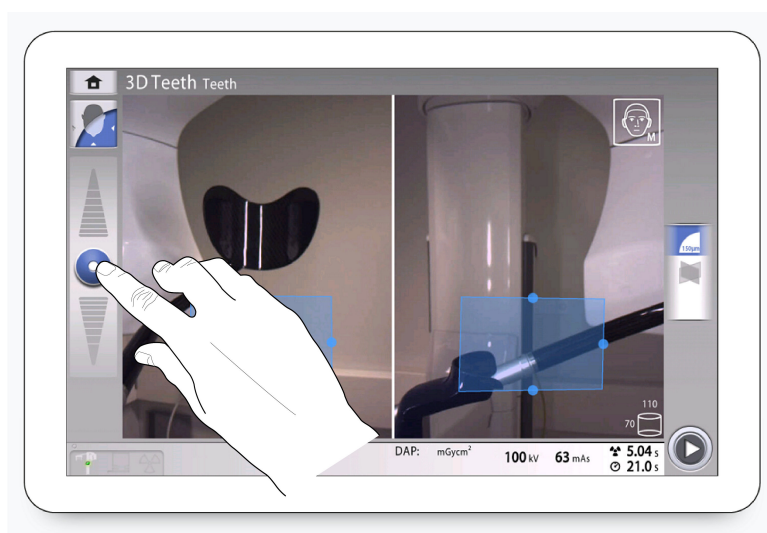

3. Ask the patient to grasp the patient handles.
4. Position the patient's head so that the patient's midsagittal plane coincides with the midsagittal plane laser light.

- The midsagittal plane laser light is shown in the middle of the patient's face.

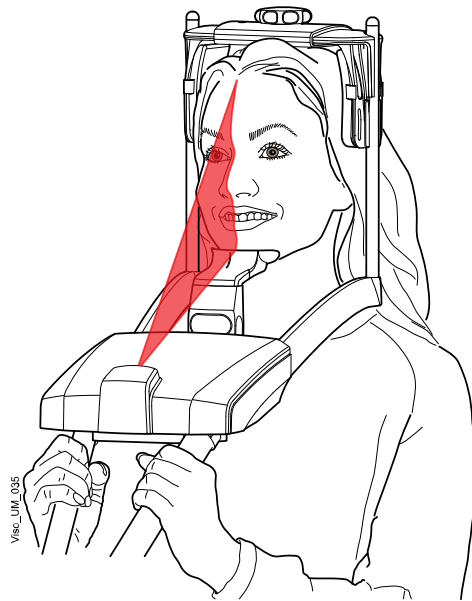

5. If you are using the rear head support:

- You can slide the rear head support up or down for optimal support of the patient's head.

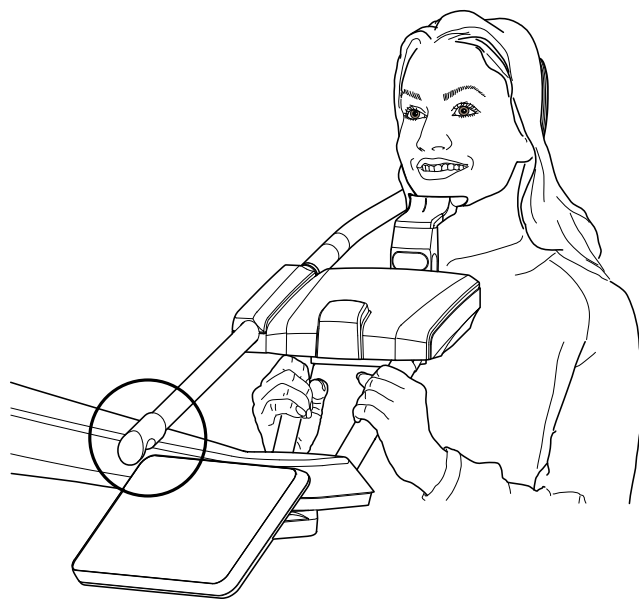

6. If you are using the top head support:

- You can adjust the head support by turning the adjusting knob at the top.
- You can use fastening straps for additional head support if needed. Refer to section "Attaching top head support" on page 27 for details.

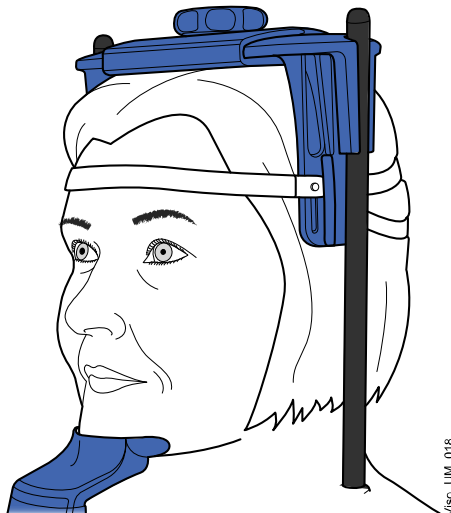

7. Select the forward button.

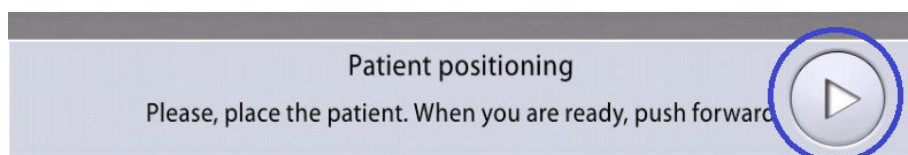

- The sensor moves to the front. You see this message.

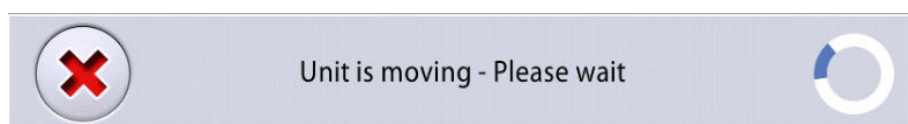

11.4 Selecting patient's left or right side

NOTE

This function is not available for the Skull program.

The sensor contains digital cameras which stream live video of the patient's head.

Use this button to select the side that you wish to expose.

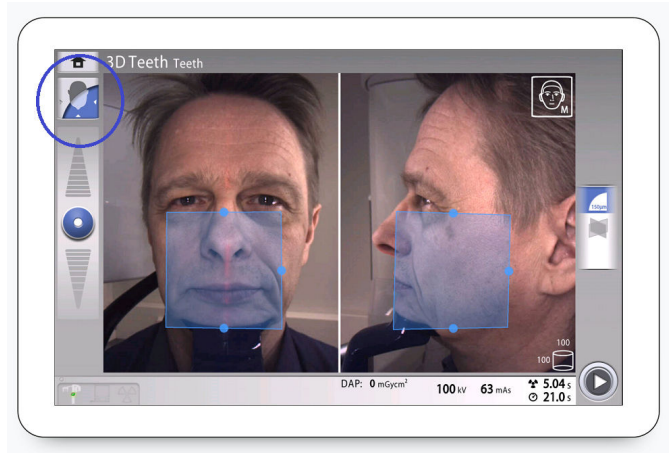

- The sensor moves to the selected side and an image of that side is shown on the screen. You see this message.

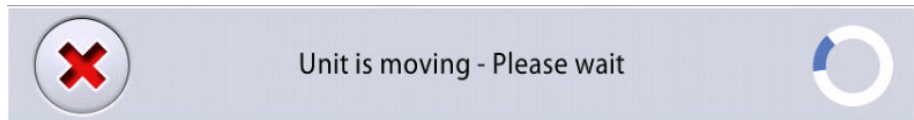

Patient's left side selected



Patient's right side selected

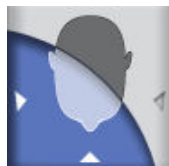

11.5 Selecting patient size

Use this button to select the patient size:

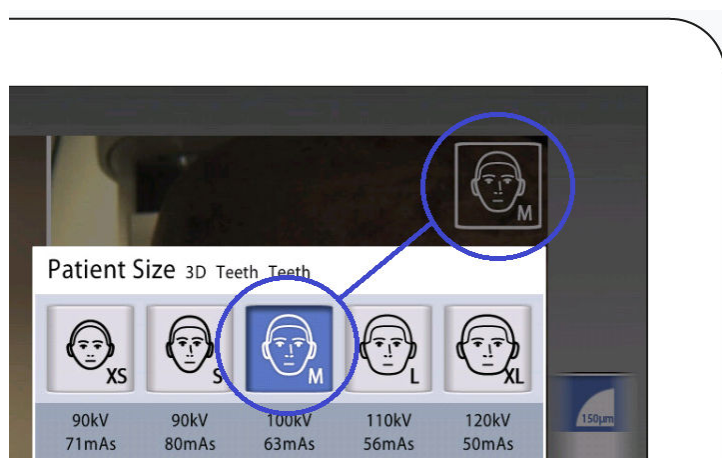

- XS = Child
- S = Small adult
- M = Medium-sized adult
- L = Large adult
- XL = Extra large adult

The preset exposure values are shown below the patient sizes.

NOTE

The exposure values will automatically change according to the selected patient size, image resolution and ULD setting. The preset exposure values are shown in section "Adjusting exposure values for current exposure" on page 50.

11.6 Adjusting image volume position and size

NOTE

This function is not available for the Skull program.

You see two camera images of the patient's head on the control panel: a front view and a side view. The preset position and size of the image volume are shown with a blue area in both views. You can use either or both views to adjust the volume position and size.

NOTE

The blue area is not an exact representation of the image volume. It is intended for visualization purposes only.

- To adjust the volume position, use your mouse cursor (virtual control panel) or finger (touch screen) to move the blue area to the anatomical region that you wish to expose. The blue area can be moved in any direction.

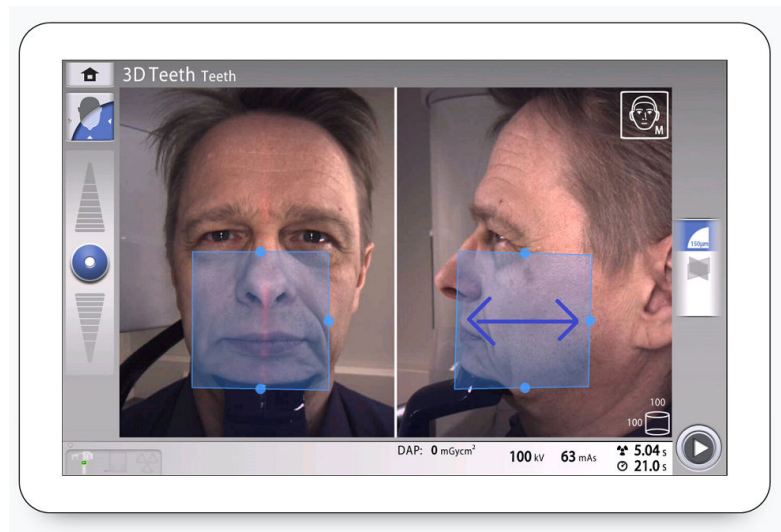

- To adjust the volume size, hold your mouse cursor (virtual control panel) or finger (touch screen) on one of the small blue balls and move the ball to enlarge or reduce the volume size. The ball turns red when you reach the limit value, i.e. when the volume diameter or height cannot be further adjusted in that direction.

The selected volume size (diameter and height) is shown in the bottom right corner of the screen.

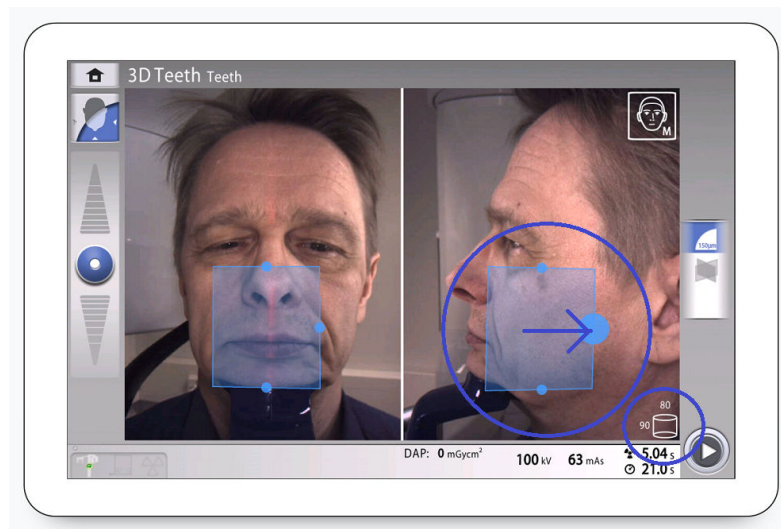

NOTE**FOR TOOTH PROGRAM:**

Alternatively, you can use this button when you select the image volume position. Select the position from the pop-up window that appears and confirm by selecting the green check mark button.

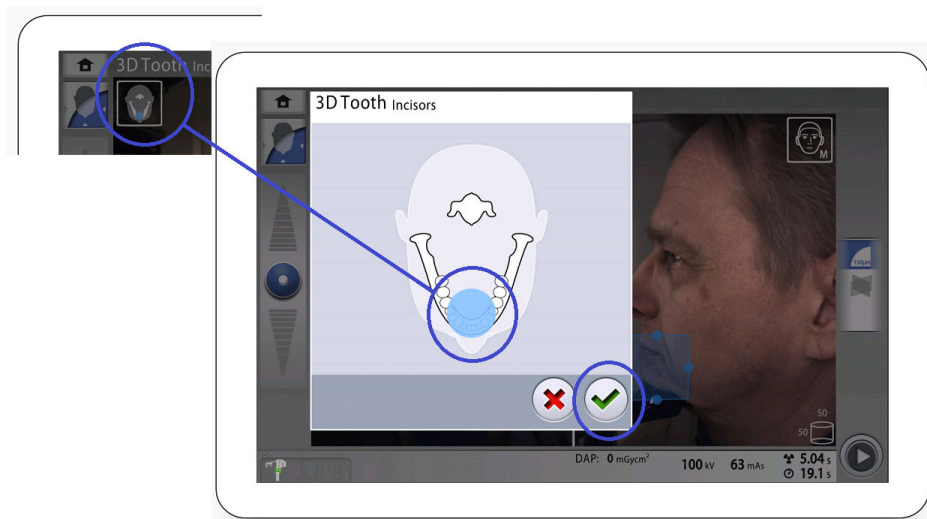

11.7 Selecting image resolution and Ultra Low Dose (ULD)

1. Select this field to open a pop-up window.
2. Select the image resolution you wish to use. The voxel size options are 600 / 450, 300, 150 and 75 micrometres.
3. Select the ULD (Ultra Low Dose) button if you want to take an exposure with a very low dose. The voxel size buttons turn green and show a small apple.
4. Select the green check mark button.

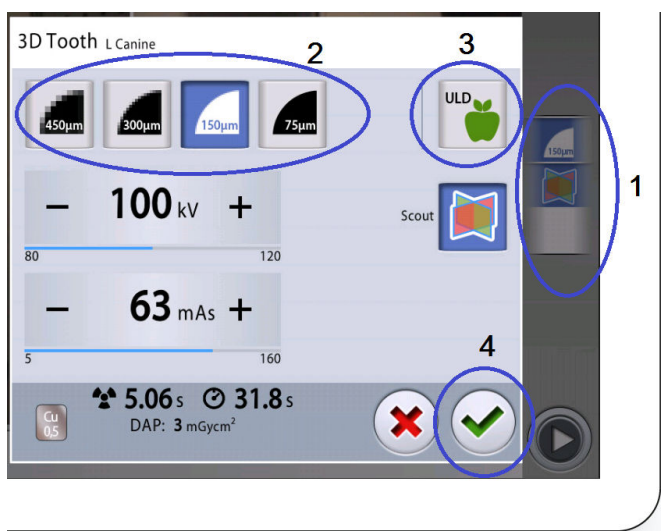
**NOTE**

The available options depend on the selected program.

NOTE

The exposure values will automatically change according to the selected patient size, image resolution and ULD setting. The preset exposure values are shown in section "Adjusting exposure values for current exposure" on page 50.

11.8 Adjusting exposure values for current exposure**NOTE**

Always try to minimize the radiation dose to the patient.

The exposure values have been preset at the factory for each patient size, image resolution and ULD (Ultra Low Dose) setting. The preset exposure values are average values and they are only meant to guide the user.

The preset exposure values are shown in the following tables.

Factory presets for voxel sizes 450 or 600 micrometres

PATIENT SIZE	kV VALUE	mAs VALUE	mAs VALUE WITH ULD
Child (XS)	90	36	7.1
Small adult (S)	90	40	8
Medium-sized adult (M)	100	32	6.3
Large adult (L)	110	28	5.6
Extra large adult (XL)	120	25	5

Factory presets for voxel size 300 micrometres

PATIENT SIZE	kV VALUE	mAs VALUE	mAs VALUE WITH ULD
Child (XS)	90	45	9
Small adult (S)	90	50	10
Medium-sized adult (M)	100	40	8
Large adult (L)	110	36	7.1
Extra large adult (XL)	120	32	6.3

Factory presets for voxel size 150 micrometres

PATIENT SIZE	kV VALUE	mAs VALUE	mAs VALUE WITH ULD
Child (XS)	90	71	14
Small adult (S)	90	80	16
Medium-sized adult (M)	100	63	12.5
Large adult (L)	110	56	11
Extra large adult (XL)	120	50	10

Factory presets for voxel size 75 micrometres

PATIENT SIZE	kV VALUE	mAs VALUE	mAs VALUE WITH ULD
Child (XS)	90	125	25
Small adult (S)	90	125	25
Medium-sized adult (M)	100	100	20
Large adult (L)	110	90	18
Extra large adult (XL)	120	80	16

If you need to adjust the preset exposure values for this exposure:

1. Select this field to open a pop-up window.
2. Use the minus or plus signs to set the exposure values you wish to use. To improve the image contrast, reduce the kV value. To reduce the radiation dose, reduce the mAs value.
3. Select the green check mark button.

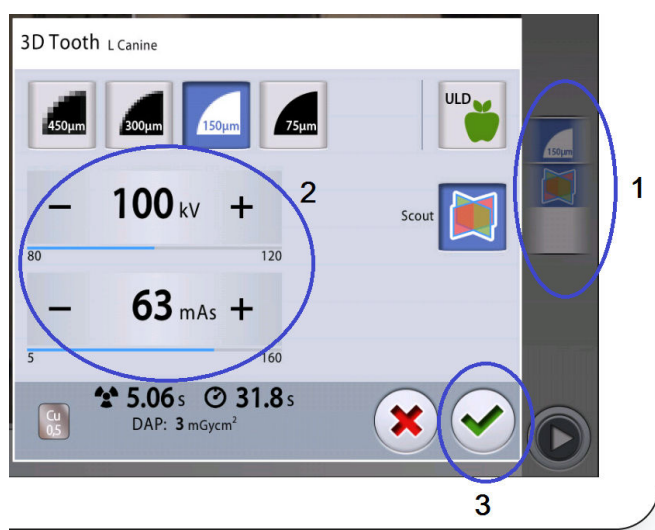

11.9 Selecting Artefact Removal Algorithm (ARA) and patient movement correction (CALM)

1. Select this field to open a pop-up window.
2. Select this button to open another pop-up window.
3. Toggle the ARA (Artefact Removal Algorithm) button to select the setting you wish to use:
 - No artefact removal



- Low



- Medium



- High



4. Select the CALM (patient movement correction) button if you wish to minimize the effects of movements on the image.

The Planmeca CALM function is an algorithm that detects patient movement during exposure and then compensates for the effects of the movement during image reconstruction. We recommend that you use this setting when taking exposures of children (patient size XS) or restless patients.

5. Select the green check mark button.

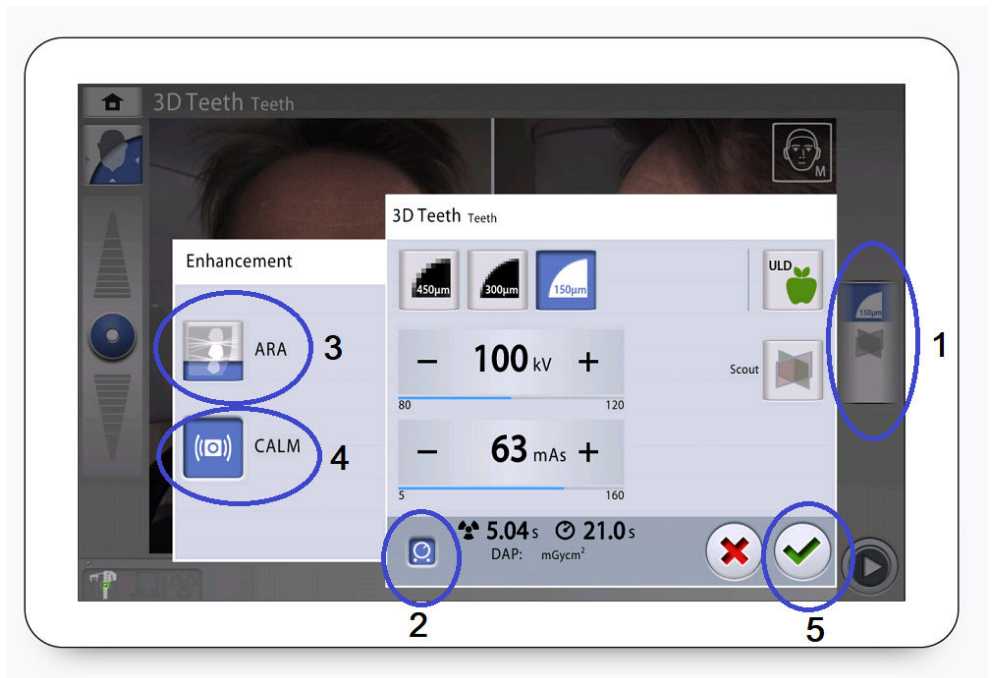

11.10 Taking scout views

NOTE

This function is not available for the Face and Skull programs.

You can take scout views of the selected image volume before you take the actual 3D image. This allows you to check that the image volume is in the correct place.

The scout views are automatically saved in the Planmeca Romexis program under 2D images (CBCT tab).

NOTE

Make sure that you have selected the correct patient in the Planmeca Romexis program.

1. Select this field to open a pop-up window.
2. Select the Scout button.
3. Select the green check mark button.
4. Select the forward button.

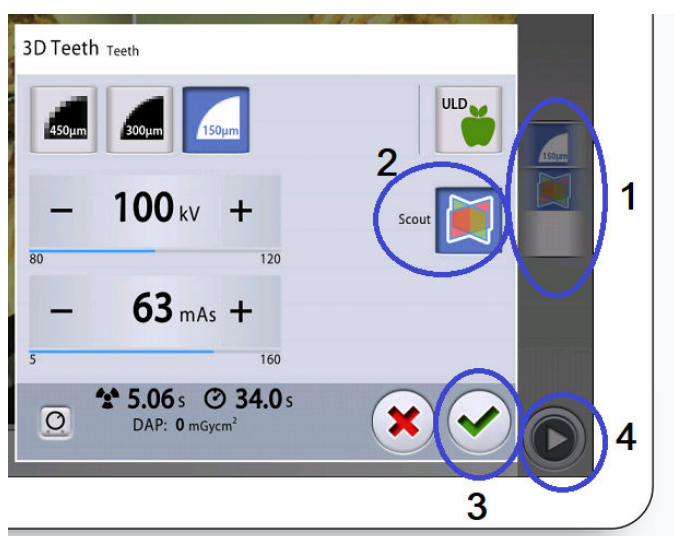

NOTE

The Scout button is already selected if you used it in the previous exposure. In this case you only need to select the forward button (step 4).

- Green lights flash on the control panel and exposure button when the X-ray system is getting ready for an exposure. You see this message.

NOTE

Move to a protected area.

Preparing for scout exposure

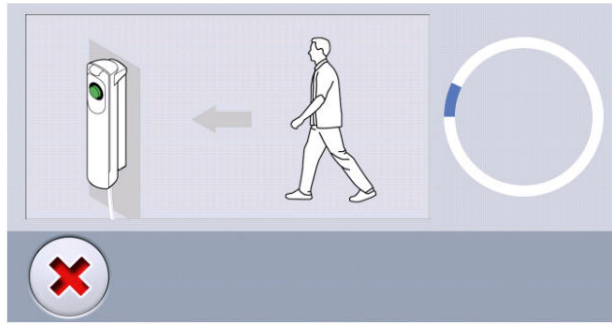

- The green lights stop flashing and stay on continuously when the X-ray system is ready for an exposure. You see this message.

Ready for scout exposure

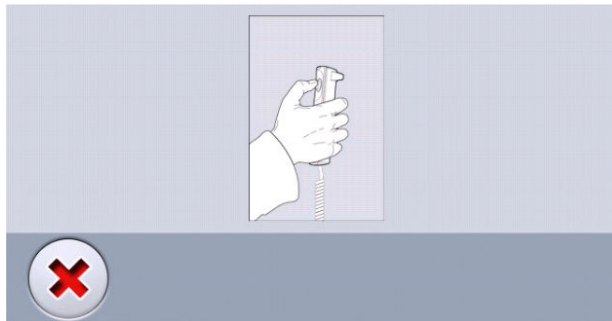

5. Ask the patient to stay as still as possible.
6. Press and hold down the exposure button for the duration of the exposure.

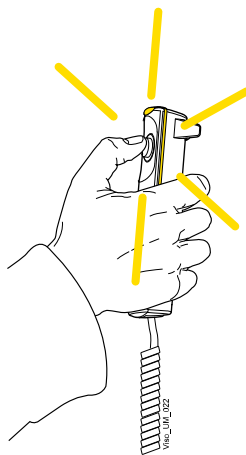

- During exposure yellow radiation warning lights illuminate on the exposure switch and on the control panel. Additionally, you hear a radiation warning tone and see a radiation warning symbol on the control panel.

7. If needed, you can now fine-adjust the volume position and size.

- To fine-adjust the volume position, use your mouse cursor (virtual control panel) or finger (touch screen) to move the blue area. The blue area can be moved in any direction.

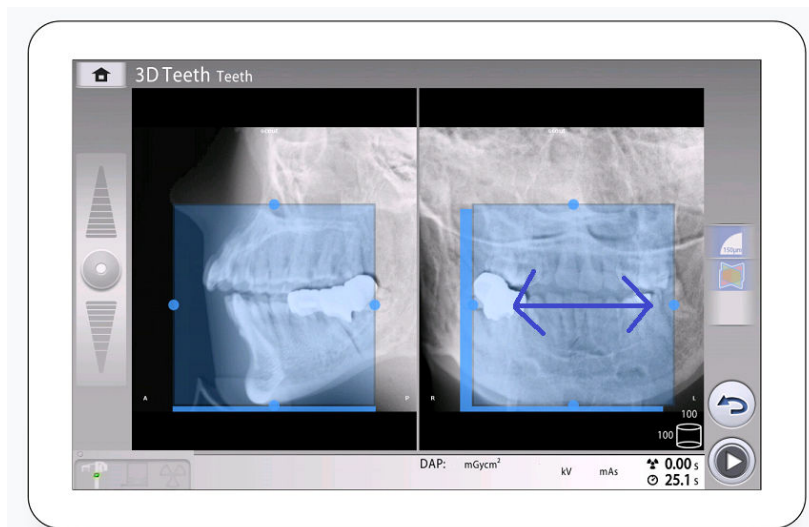

- To fine-adjust the volume size, hold your mouse cursor (virtual control panel) or finger (touch screen) on one of the small blue balls and move the ball to enlarge or reduce the volume size. The ball turns red when you reach the limit value, i.e. when the volume diameter or height cannot be further adjusted in that direction. The selected volume size (diameter and height) is shown in the bottom right corner of the screen.



- The adjustment is indicated by different blue shades:
 - Dark blue area = Volume position and size before adjustment
 - Light blue area = Volume position and size after adjustment

- If you then want to take new scout views, select this button and take a new exposure as described above. Make new fine-adjustments until the image volume is in the correct place.

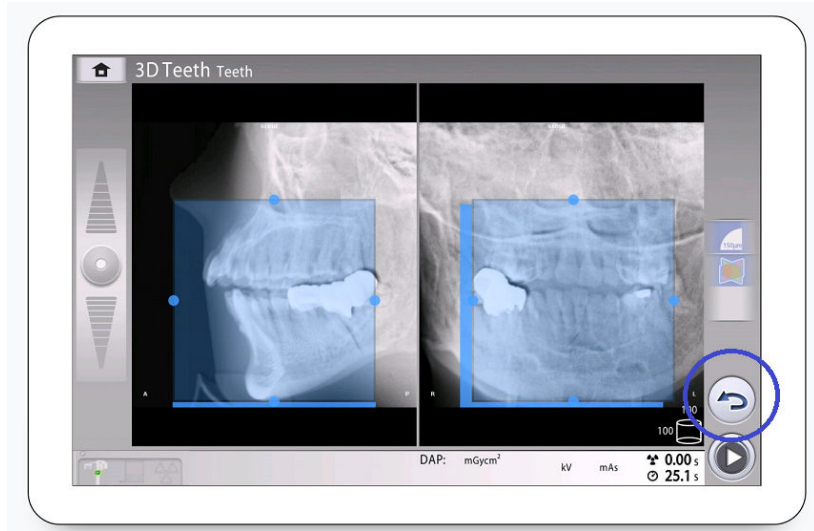

11.11 Taking a 3D exposure

NOTE

Make sure that you have selected the correct patient in the Planmeca Romexis program.

NOTE

After scout views the X-ray system is automatically ready for a 3D exposure. Go directly to step 2.

NOTE

Make sure that the Scout button is switched off if you do not want to take scout views first.

- Select the forward button.

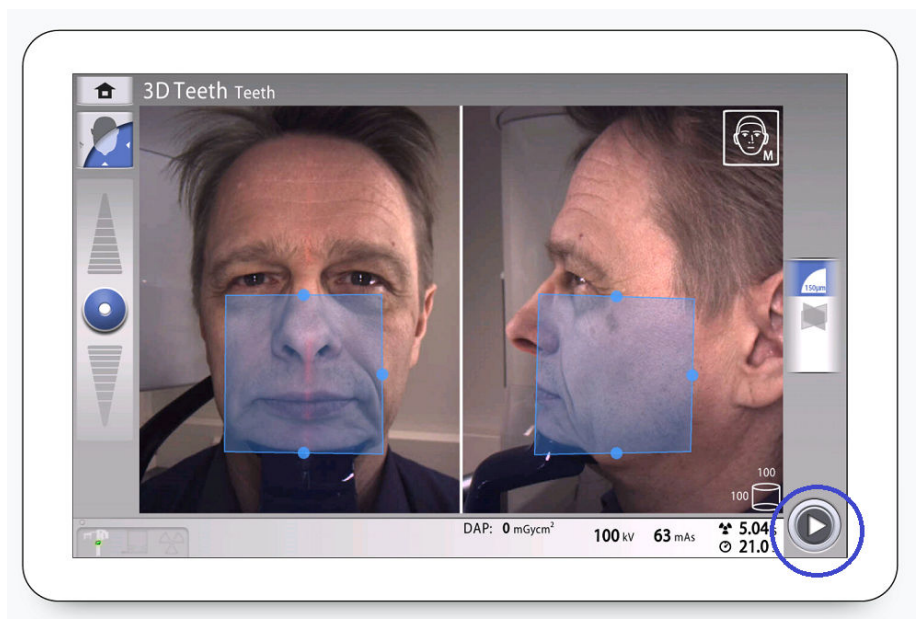

- Green lights flash on the control panel and exposure button when the X-ray system is getting ready for an exposure. You see this message.

NOTE

Move to a protected area.

Preparing for exposure

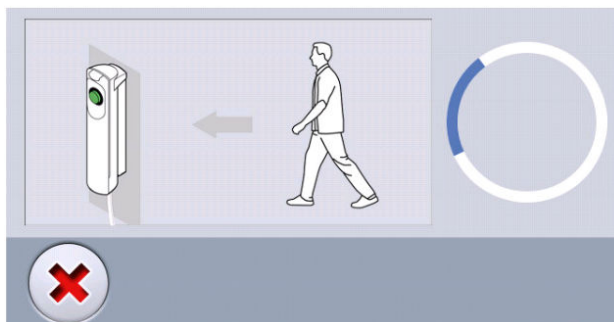

- The green lights stop flashing and stay on continuously when the X-ray system is ready for an exposure. You see this message.

Ready for exposure

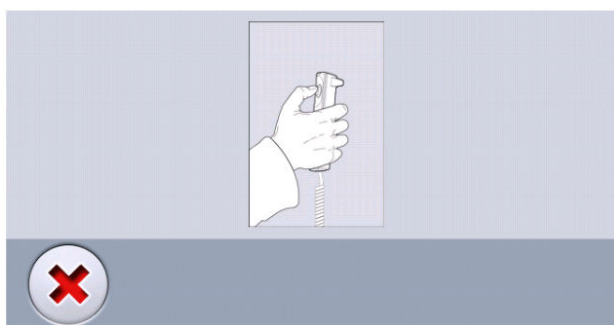

2. Ask the patient to stay as still as possible.
3. Press and hold down the exposure button for the duration of the exposure(s).

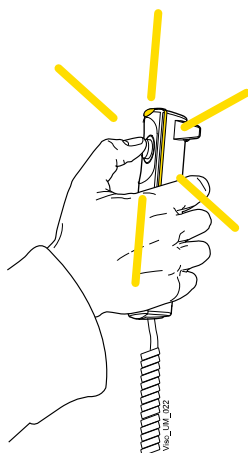

The C-arm moves around the patient's head.

- During exposure yellow radiation warning lights illuminate on the exposure switch and on the control panel. Additionally, you hear a radiation warning tone and see a radiation warning symbol on the control panel.
- If you take a skull exposure with two image volumes, the lower volume (1 / 2) is imaged first and the upper volume (2 / 2) last. The C-arm is automatically moved up between the volumes.
- You can follow the imaging process on the virtual control panel. You see two preview images: the progress bar below the first image (1) shows the capture progress and the slider below the second image (2) allows you to view the captured frames from different angles.

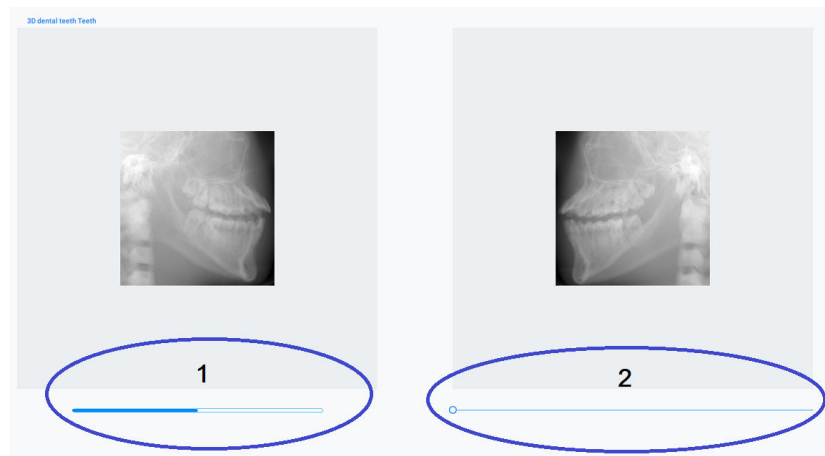

NOTE

Do not release the exposure button before the end of the exposure(s).

NOTE

Maintain audio and visual contact with the patient and X-ray unit during exposure. If the C-arm stops moving during exposure, or moves in an erratic way, release the exposure button immediately.

4. You see this message on the touch screen.
 - Select this button if you want to move the sensor to the back so that the patient can leave the X-ray unit.

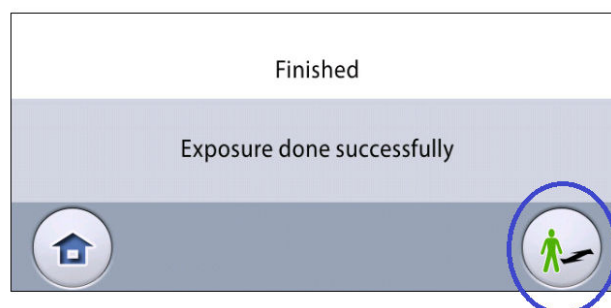

- Select this button if you want to go to the home screen.

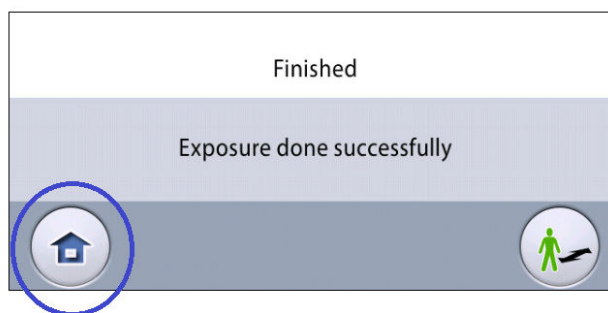

5. Remove the fastening straps (if used). Release the patient from the head support.
6. Guide the patient away from the X-ray unit.
7. The image is shown on the computer screen.
 - The image processing time depends on the selected settings. For example, if you selected the ULD (Ultra Low Dose) button, you have to wait longer before the image appears.
 - If you took a skull exposure with two image volumes, you must accept the image stitching function in the Planmeca Romexis program.

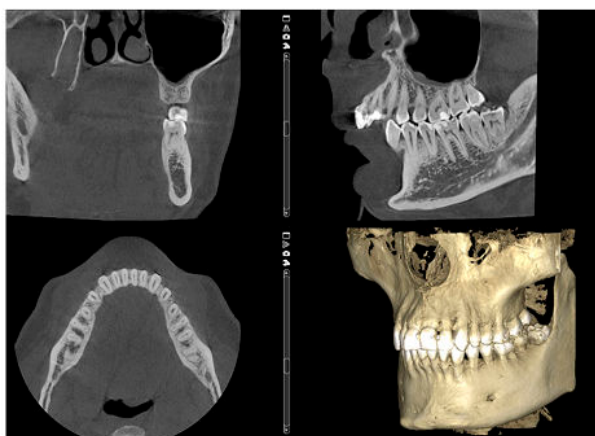

12 3D quality control

A quality control test must be carried out on the X-ray unit once a month in order to ensure consistent image quality.

A separate software program called Planmeca Device Tool QA has been installed on your computer for this purpose.



NOTE

The views shown here are from software version 5.0.1. The views may be slightly different in later software versions. To check the software version of your Planmeca Device Tool QA program, go to Info > About.

12.1 Tools required

Remove any patient supports attached to the X-ray unit. Attach this test phantom into the adapter.

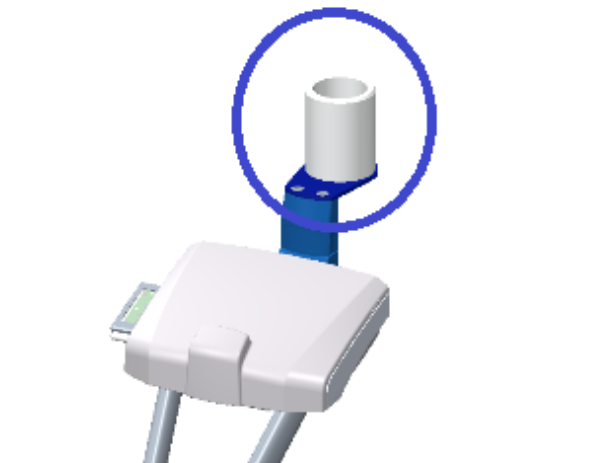

12.2 Test procedure

1. Start the Device Tool QA program on your computer.

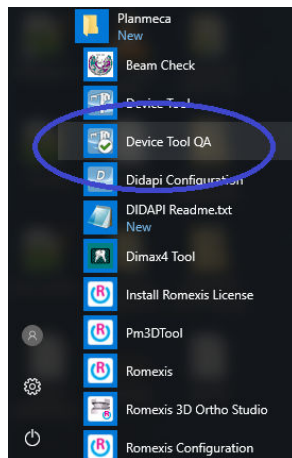

2. Select the Viso button.

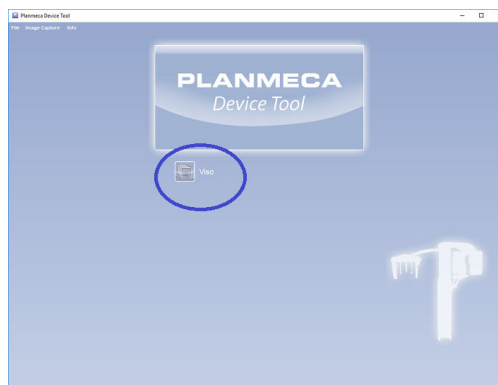

3. On the next screen, select the
 - option Viso Production and
 - QA VISO button at the bottom of the screen.

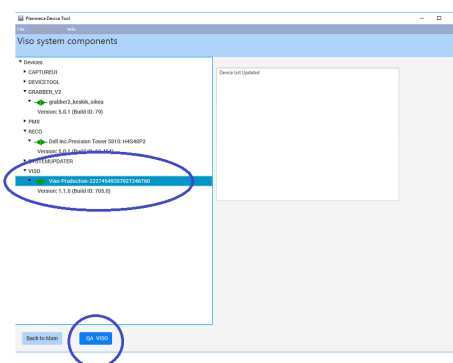

8. Select the Next button at the bottom of the screen.

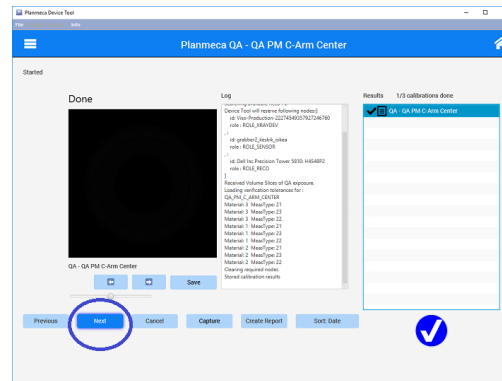

9. Take a second exposure as instructed in steps 5 and 6.

10. Select the Next button at the bottom of the screen.

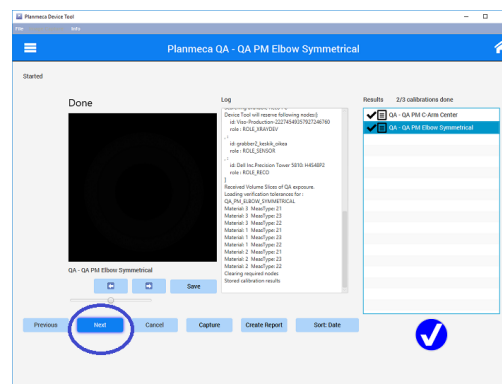

11. Take a third exposure as instructed in steps 5 and 6.

12. Select the Create report button at the bottom of the screen.

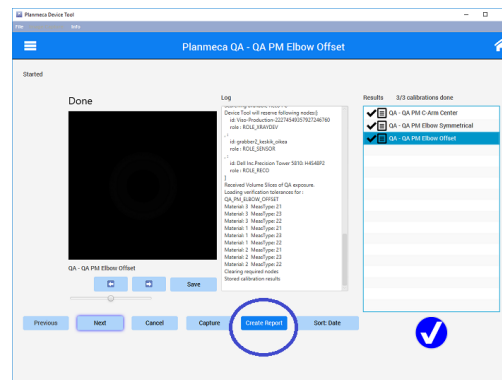

The test report opens in your web browser.

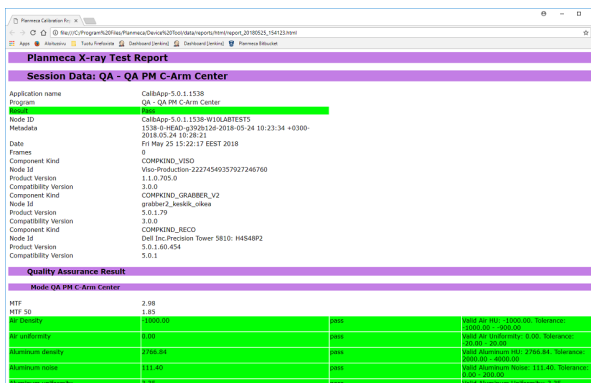

- To save the test report, first select the command Save As from the File menu. Then choose the location and give the test report a name (e.g. QATestReport_May2018). Finally click Save.

NOTE

The procedure for saving the test report may vary depending on the browser you are using. Refer to the help section of your browser for details.

- Select this cross to close the Device Tool QA program.

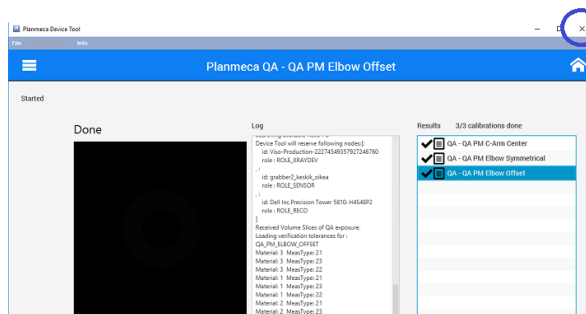

12.3 Evaluating test results

Evaluate the test results according to the following table:

	Unit to be measured	Recommended test frequency	Performance criteria
1	MTF (Modulation Transfer Function)	Monthly	> 1 lp/mm
2	HU (Hounsfield unit)	Monthly	Max. difference between measured average value and baseline value A: Acryl: 50 HU B: Aluminium: 200 HU C: Air: 50 HU

	Unit to be measured	Recommended test frequency	Performance criteria
3	SNR (Signal-to-Noise Ratio)	Monthly	Max. difference between measured average value and baseline value +/- 20%

- The baseline values are your reference values. They were established when the X-ray system was first installed or when any major changes were made to the X-ray system.
- Tomographic sections with CBCT (Cone Beam Computed Tomography) are very thin. Their thickness is set by the size of the detector elements which remain constant during product life. Therefore it is not necessary to measure the thickness.
- SNR (Signal-to-Noise Ratio) is used to measure low contrast resolution.

NOTE

If any of the measured values do not meet the set criteria, repeat the QA test. If the problem persists, contact your service technician for help.

NOTE

In order to be able to compare the test results, it is essential to use the same equipment and accessories for both tests.

13 Help messages

The X-ray unit incorporates a self-checking feature that monitors the operation of the unit. If the system detects an operating error, a help message (e.g. H101) appears on the control panel.

The X-ray unit will not accept any commands from the user until the help message is cleared. Clear the message by selecting the green check mark button.

The following list shows, in numerical order, all the help messages that can appear.

Code	Explanation		Comments
H101	Exposure switch	The exposure button was released before the end of the exposure.	Guide the patient away from the X-ray unit before moving the C-arm. Press and hold down the exposure button for the entire duration of the exposure.
H102		The exposure button is stuck or the cable is short circuited.	Release the exposure button. Contact your service technician if you need to replace the exposure switch.
H105	Emergency stop button	The emergency stop button has been activated.	All movements of the X-ray unit are blocked and no radiation is generated. Guide the patient away from the X-ray unit. Then release the emergency stop button to resume normal operation.
H130	Patient safety area	Patient safety area violation detected.	
H131	Rear head support	Rear head support movement detected.	
H132		Rear head support detached.	
H133		Remove the rear head support.	
H134		Adjust the rear head support.	

Code		Explanation	Comments
H141	Height movement	Movement stopped because the column is moving in wrong direction.	The column is moving in wrong direction, check sensors and cables.
H142		Height movement is not possible because the stop plate at the bottom of the column was activated.	Clear any obstruction before moving the column again.
H146		Motor safety switch in upper direction z drive	
H147		Motor safety switch in lower direction z drive	
H148		Height movement is not possible. The position of the patient support base is too high.	Use the height adjusting slider to move the patient support base down.
H149		Height movement was stopped because the C-arm cannot be moved higher.	Clear any obstruction before continuing.
H150		Height movement was stopped because the patient support base cannot be moved lower.	Clear any obstruction before continuing.
H151		Line voltage	The line voltage was too low during exposure.
H152	The line voltage is too low.		Exposure is not possible. Contact your service technician for help.
H153	Height movement	Z column is too high.	
H154		Z column is too low.	
H155		Imaging equipment is too high.	
H156		Imaging equipment is too low.	
H157		Imaging equipment movement timeout.	
H158		Imaging equipment position sensor not working properly.	
H159		Z column position sensor not working properly.	
H160		Imaging equipment is moving in wrong direction, check sensors and cables.	

Code	Explanation	Comments	
H161	Temperature	The temperature of the tube head is too high.	Wait for a few minutes for the tube head to cool down.
H162		The temperature of the lift motor is too high.	Wait for a few minutes for the lift motor to cool down.
H165		The temperature of the tube head is too high for the selected exposure values.	Wait for a few minutes for the tube head to cool down.
H166		The maximum tube head energy level was exceeded.	Wait for a few minutes for the tube head to cool down or use lower exposure values.
H170	User related messages	Wrong licence code.	Check the licence code.
H171		Timeout in production test.	
H181		The imaging process was cancelled in Planmeca Romexis.	
H182		Timeout in image data transmission.	Exposure was interrupted. Contact your service technician for help.
H186		No IP address defined for 3D sensor.	
H187		Problem during image data transmission.	Exposure was interrupted. Contact your service technician for help.
H189		The screen was touched during exposure.	Exposure was interrupted.
H190		Protouch-CPU communication failure.	
H191		3D sensor communication failure.	
H192		Workstation communication failure.	
H193		Invalid scan settings.	
H194		CPU connection not established.	
H195		Request timed out while waiting for CPU to respond.	
H196		Version mismatch in communication interfaces.	
H197		Workstation communication disabled.	
H199	Video streaming failed.		

14 Error messages

NOTE

Contact your service technician for help if you receive an error message.

The X-ray unit incorporates a self-checking feature that monitors the operation of the unit. If the system detects a technical fault, an error message (e.g. E201) appears on the control panel.

An error message indicates that the X-ray unit has a problem that needs to be solved before further exposures can be taken. The X-ray unit will not accept any commands from the user until the error message is cleared. Guide the patient away from the X-ray unit. Then clear the message by selecting the green check mark button.

15 Cleaning and disinfection

NOTE

Switch the X-ray unit off before cleaning and disinfection.

NOTE

Use a Planmeca approved cleaning agent and surface disinfectant. The products are categorised here as cleaning agents and / or disinfectants according to the information provided by the manufacturers.

NOTE

Follow the instructions provided by the manufacturer of the cleaning agent, disinfectant and autoclave.

NOTE

FOR SPRAYS, LIQUIDS AND FOAMS:

Do not apply sprays, liquids or foams directly on the surfaces. Apply sparingly to a clean soft cloth and wipe the surface with the cloth.

Contact your service technician for help if sprays, liquids or foams enter the system.

Planmeca approved cleaning agents

Manufacturer	Brand name
Alpro Medical	CleanWipes
Alpro Medical	IC-100
Alpro Medical	MinutenSpray-classic
Clinell	Clinell Universal Wipes
Clinitex	R515 Detergent Multi-Surface Wipes
Ecolab	Actichlor Plus
SciCan	Optim Blue Wipes

Planmeca approved surface disinfectants

Manufacturer	Brand name
Alpro Medical	MinutenSpray-classic
Antibac	Antibac 75%
CCS HealthCare	Dax Extra
CCS HealthCare	Dax 70+
Chemi-Pharm AS / Plandent	Orbis Surface Disinfectant
Clinell	Clinell Universal Wipes
Ecolab	Actichlor Plus
SciCan	Optim Blue Wipes

15.1 Patient supports, patient handles and touch screen

Wipe these parts after each patient using a Planmeca approved surface disinfectant.

Use a Planmeca approved cleaning agent for cleaning stains and dirt if needed.

Patient supports

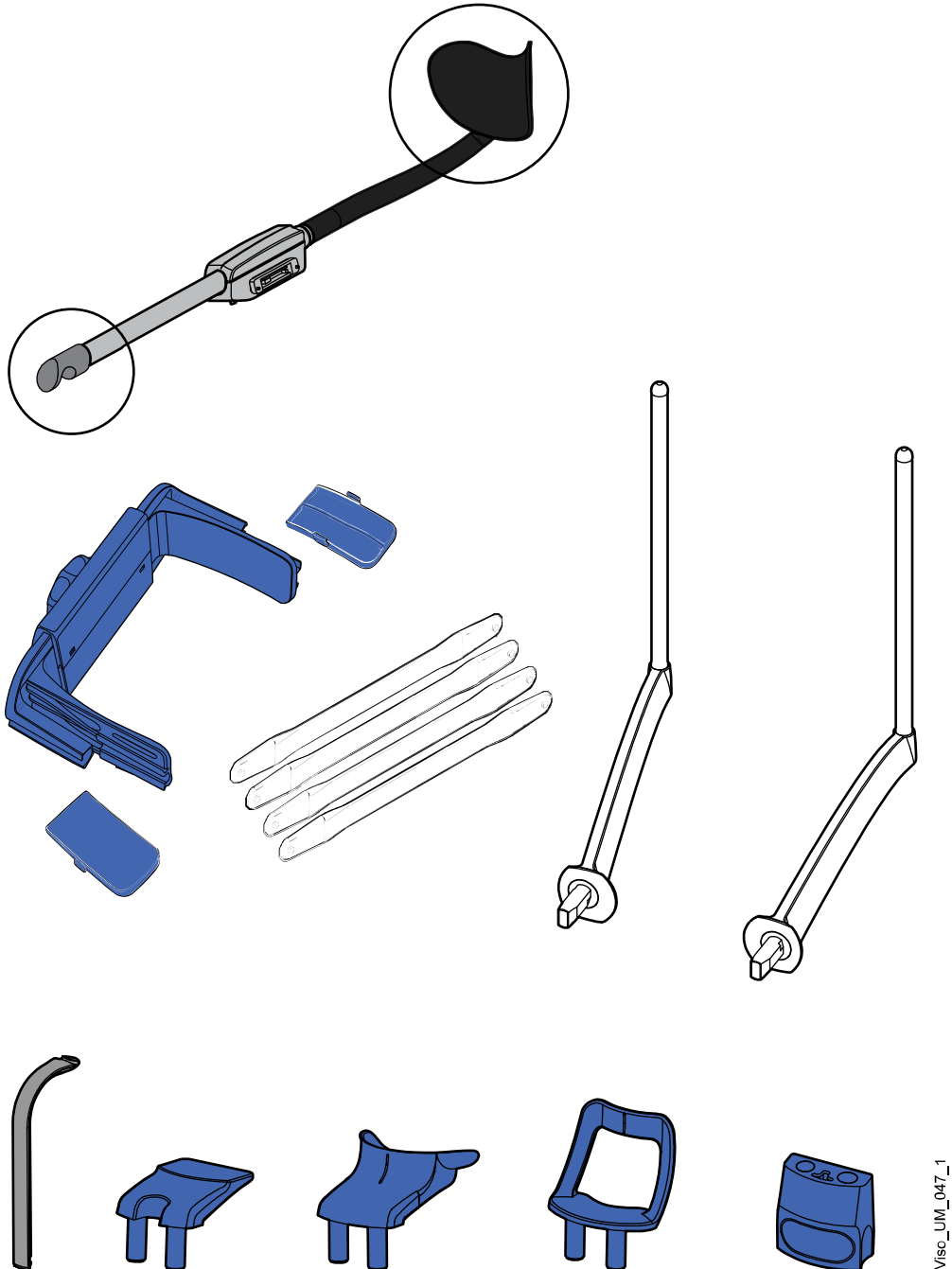

Patient handles and touch screen

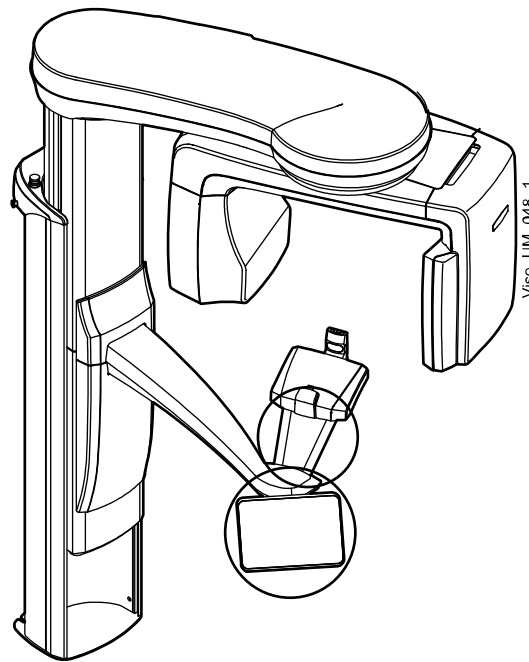

NOTE

These parts can be autoclaved at 134°C (273°F). They can be autoclaved at least up to 100 times.

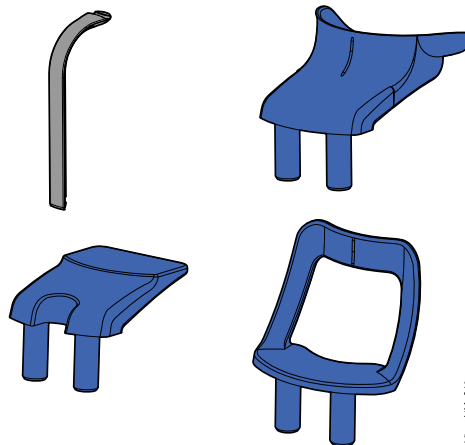

15.2 Other surfaces

Wipe the other surfaces regularly using a Planmeca approved surface disinfectant.

Use a Planmeca approved cleaning agent for cleaning stains and dirt if needed.

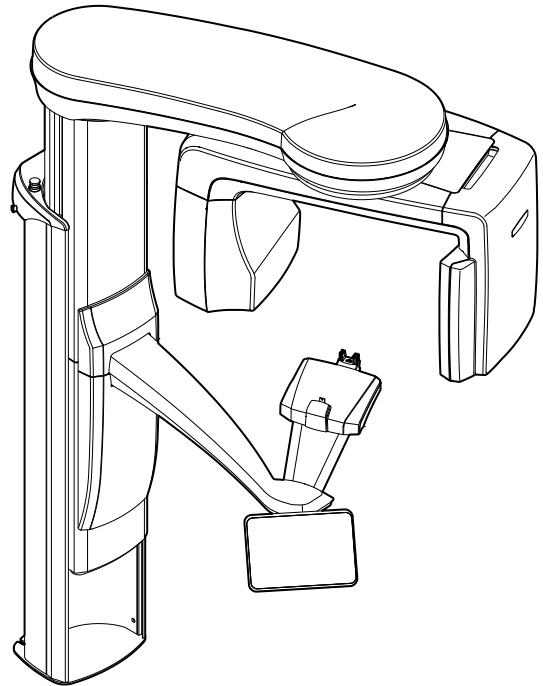
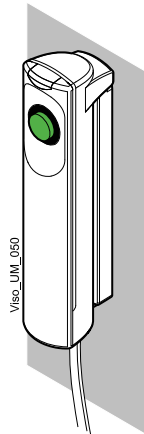

16 Service

The X-ray unit must be checked by a qualified Planmeca service technician once a year or after every 10 000 exposures (if this is sooner). This will guarantee patient and user safety and ensure consistent image quality.

The annual maintenance service includes inspection of the following:

- X-ray unit adjustments and quality control checks
- data security updates
- exposure switch
- exposure indicator lights and warning signals
- emergency stop button
- column motor nut
- labels

17 Disposal

In order to reduce the environmental load over the product's entire lifecycle, Planmeca's products are designed to be as safe as possible to manufacture, use and dispose of.

Parts which can be recycled should always be taken to the appropriate processing centers, after hazardous waste has been removed. Disposal of obsolete units is the responsibility of the waste possessor.

All parts and components containing hazardous materials, as well as batteries, must be disposed of in accordance with waste legislation and instructions issued by the environmental authorities. Batteries must be disposed of in compliance with the requirements of Directive 2006 / 66 / EEC.

The risks involved and the necessary precautions must be taken into account when handling waste products.

NOTE

FOR 3D RECONSTRUCTION PC:

Delete all patient data from the hard drive before disposal. Use special sanitizing software that cleans the media or physically destroy the hard drive.

Part	Main material for disposal	Recyclable material (X) = if available	Waste disposal site	Hazardous waste (separate collection)
Frame, covers and patient supports: • metal	aluminium	X		
	galvanized steel	X		
	lead			X
Frame, covers and patient supports: • plastic	PUR		X	
	other plastics	X		
Motors		(X)		
Component boards		(X)		
Cables, transformers	copper	X		
	steel	X		
	transformer oil			X
X-ray tube				X
Packing	wood	X		
	cardboard	X		
	paper	X		
	polystyrene	X		
Sensor	Return sensor to Planmeca.			
Other parts			X	

18 Technical specifications

NOTE

Refer to the Technical Manual for details.

18.1 Technical data

Classification	
Medical Device Directive	93/42/EEC (Class IIb)
RoHS	2011/65/EU
IEC 60601-1	Class I, type B
CISPR 11	Class B
IP Classification	IPX0
Applied parts (according to IEC 60601-1: 2012)	
Patient supports	As shown in section Patient supports in User Manuals
Patient handles	
Generator (according to IEC 60601-2-7: 1998)	
	Resonant-mode, DSP-controlled, 80 - 160 kHz
X-ray tube	
	Toshiba D-059SBR or SXR 130-10-0.5 SC
Focal spot size (according to IEC 60336: 2005)	
	0.5 x 0.5 mm
Filtration	
3D	Total 2.5 mm Al + 0.2 mm / 0.5 mm Cu
Pan (SmartPan) / ProCeph	Total 2.5 mm Al
Tube housing front cover quality equivalent filtration (not included in the specified total filtration)	0.3 mm Al @ 70 kV / HVL 2.6 mm Al
Anode voltage	
3D	80 - 120 kV $\pm 5\%$
Pan (SmartPan)	60 - 84 kV $\pm 5\%$
ProCeph	60 - 84 kV $\pm 5\%$
Anode current	
3D	Toshiba D-059SBR: 1-12.5 mA $\pm 10\%$ SXR 130-10-0.5 SC: 1-16 mA $\pm 10\%$
Pan (SmartPan)	Toshiba D-059SBR: 1-14 mA $\pm 10\%$ SXR 130-10-0.5 SC: 1-16 mA $\pm 10\%$
ProCeph	Toshiba D-059SBR: 14 mA $\pm 10\%$ SXR 130-10-0.5 SC: 16 mA $\pm 10\%$
mAs range	
	min. / max. as indicated $\pm(10\% + 0.2 \text{ mAs})$
Dose range and accuracy	

	Dose range min. / max. as indicated on system user interface. Accuracy of dosimetric indication (DAP, CTDI): $\pm 40\%$
Linearity of radiation output	
	< 0.1
Exposure time	
3D	Pulsed, effective 1.5 - 36 s as indicated $\pm 10\%$
Pan (SmartPan)	2.5 – 15.6 s as indicated $\pm 10\%$
ProCeph	0.1 – 1.6 s as indicated $\pm 10\%$
SID	
3D / Pan (SmartPan)	700 mm
Ceph	1700 mm (66.9 in.)
Magnification	
3D	1.40 - 1.71
Pan (SmartPan)	1.40
Ceph	1.13
Duty cycle for height adjustment	
	25 s ON / 400 s OFF
Line voltage	
	100 - 220 V~ / 50 - 60 Hz 230 - 240 V~ / 50 Hz
Line current	
	8 - 17 A
Input power	
Stand by	150 VA
Exposure	1800 W
Line harmonics	
	Cos better than 0.9
Max. permissible apparent impedance of supply mains	
	0.5 ohm (100 VAC)
Max. continuous heat dissipation	
	250 W
Internal fuse(s)	
One user replaceable fuse	100 - 220 V~ / 16A FF H 500 V 230 - 240 V~ / 8A FF H 500 V
Type	195100 ELU
External fuse(s)	
	100 - 220 V ~ / 16A min. - 20A max. T 250 V 230 - 240 V ~ / 10A min. - 20A max. T 250 V

Battery	
	Lithium battery: 3V, CR2032, Panasonic / Varta
Max. weight	
Base unit	165 kg (364 lb)
ProCeph	20 kg (44 lb)
Environmental requirements	
Transport:	
Temperature	-20°C - +60°C (-4°F - +140°F)
Relative humidity	10 - 90% RH (non-condensing)
Air pressure	700 - 1060 hPa
Storage:	
Temperature	-10°C - +50°C (+14°F - +122°F)
Relative humidity	10 - 90% RH (non-condensing)
Air pressure	700 - 1060 hPa
Operating:	
Temperature	+10°C - +35°C (+50°F - +95°F)
Relative humidity	10 - 90% RH (non-condensing)
Air pressure	800 - 1060 hPa
Max. altitude	2000 m (1.25 miles)
Image properties	
ProCeph:	
Flat panel pixel size	139 µm
Flat panel active surface	302 x 249 mm (11.89 x 9.80 in.)
3D:	
Flat panel pixel size	139 µm
Flat panel active surface	299.7 x 246.3 mm (11.80 x 9.70 in.)
Pan (SmartPan):	
Flat panel pixel size	139 µm
Flat panel active surface	8 - 25 x 146 mm (0.31 - 0.98 x 5.74 in.)
Operating requirements for ProFace program	
Optimum colour temperature	Approx. 6500 Kelvin
Even and uniform lighting	
No bright lights	

18.2 Original manufacturer

PLANMECA Oy, Asentajankatu 6, FIN-00880 Helsinki, FINLAND

Phone: +358 20 7795 500, www.planmeca.com

PLANMECA

Planmeca Oy | Asentajankatu 6 | 00880 Helsinki | Finland

tel. +358 20 7795 500 | fax +358 20 7795 555 | sales@planmeca.com | www.planmeca.com

